

PROFESSIONAL PARTNER EDITION



HAYN WIRE RIGGING

MANUFACTURER OF QUALITY HARDWARE



WWW.HAYN.COM

About Us:

Hayn has been engineering and manufacturing marine, architectural, and industrial rigging hardware since the late 1950's. Hayn's commitment to advanced automation, latest design technology, and manufacturing techniques give us a distinct advantage over our competitors. Hayn offers short lead-times for both our standard products as well as custom components. Hayn's corporate culture includes a highly specialized team that endlessly seeks opportunities for improvement to quality and product features, as well as customer service.

Product Traceability / Quality Control:

All Hayn products have full traceability including raw material certificates and certificates of conformity. Requirements for this documentation should be indicated at time of order. Hayn employs a comprehensive quality system that includes thorough review of any non-conformance of products, internal processes, etc.

Specifications:

Product specifications are subject to change without notice. Catalog images are representative of the product type/family and may not reflect the item purchased. Product drawings are available upon request which include the most recent and accurate information available.

Custom Rigging Products:

Hayn carries a comprehensive standard product offering. In the event that the products required for your rigging application differ from those that are standard catalog items, Hayn will produce custom components to your specifications. Please contact us for pricing and lead-times.



Customer Service:

Our dedicated, knowledgeable sales staff is continually trained on the latest Hayn products and features. During normal business hours, we are available to answer any questions concerning our rigging hardware. Our goal is to have the person who answers the phone be able to help with the most commonly asked questions. However, application questions should be directed to your local Rigger as they are your best source for this type of information. Please contact Hayn for the Dealer or Rigger nearest you.

Wholesale Sales (Exclusively):

Hayn manufactures and distributes quality marine products exclusively for the rigging trade. All orders are strongly encouraged to exceed \$100 as a minimum. Possession of this catalog does not constitute an agreement to sell. Please contact us directly for an applicable Hayn Dealer or Rigger nearest you.

Ordering Methods Include:

E-mail – sales@hayn.com
Phone – 800-346-4296
Fax – 800-441-4296

Payment:

Payment terms are Net 30 Days for established accounts. All major Credit Cards are accepted. Prepayment or C.O.D. shipment is required for first time orders or until account terms are established. Past due accounts will transfer to C.O.D. status and are subject to a 1-1/2% finance charge added per month until the balance is paid in full. Payment discounts will not be allowed on invoices with account balances that are past due.

Freight:

All freight costs are the responsibility of the customer. Freight and insurance charges will be added to the invoice at time of shipment. All C.O.D. shipments are subject to an applicable transaction fee. All small package ground and air shipments can be shipped via UPS or FedEx. Larger shipments may be sent through a common carrier. Shipments with other carriers may incur additional charges.

Returns:

Special order or custom items may not be returnable. Only current version product inventory will be accepted for credit. Credit values are based on original invoice value. Product returned after 60 days from time of shipment is subject to a restocking charge of 10%. Product returned must have a Hayn issued RMA (Return Merchandise Authorization) number.

Return address:

Hayn Enterprises

51 Inwood Road
Rocky Hill, CT 06067 USA

Attn: Returns Department – RMA# _____

Warranty:

Hayn Marine hardware manufactured by Hayn Enterprises, LLC is guaranteed at time of shipment to be free of defects in material and craftsmanship and only when used for the purpose intended. Hayn does not accept responsibility for product used in applications where safe working loads are exceeded, product has been improperly installed, and/or product has been modified.

Hayn makes no representations for suitability to a particular application.

Warranty is limited to repair or replacement, at Hayn's discretion, of the warranted part only.

Hayn Enterprises, LLC does not, under any circumstance, assume responsibility for any incidental damages incurred in connection with the use of its products. All hardware manufactured by Hayn Enterprises, LLC carries a limited lifetime warranty.

**Hayn Enterprises, LLC**

51 Inwood Road, Rocky Hill, CT 06067 USA
Tel: 860-257-0680 Fax: 860-257-0683
E-mail: sales@hayn.com | www.hayn.com

WIRE RIGGING PRODUCTS CATALOG

PART FEATURE LETTER DESIGNATION KEY

A - Jaw Depth

B - Body Diameter

C - Fully Closed (Adjustment Range)

D - Pin or Hole Diameter

E - Jaw Gap

F - Jaw Width or Eye Width or Fork Diameter

G - Grip Length

H - Hardware Factor

HD - Head Diameter

HT - Head Thickness

J - Eye Width / Boss Width

L - Length

O - Fully Open (Adjustment Range)

P - Thread Size, Pitch, and Direction

R - Retaining Pin Hole

RAD - Radius

T - Thread Length

W - Wire Diameter



TABLE OF CONTENTS



WIRE ROPE & SWAGE FITTINGS

Pg.6



TURNBUCKLES

Pg.20



HI-MOD COMPRESSION TERMINALS & FAILSAFE INSULATORS

Pg.34



THREADED FITTINGS

Pg.44



LIFELINE HARDWARE

Pg.50



ADDITIONAL HARDWARE & TOOLS

Pg.68

WIRE ROPE & SWAGE FITTINGS

- 7** Swage Dimensions Table
- 8** Stainless Steel Wire Rope
- 10** Swage Marine Eyes
- 11** Swage Rigging Toggles
- 12** Swage Rigging Studs
- 14** Swage Forks
- 15** Swage Aircraft Eyes / Aircraft Forks
- 16** Swage Stemball Terminals
- 17** Swage "T" Terminals
- 18** Swage Shroud Terminals
- 19** Swage Rigging Adjusters



SWAGE DIMENSIONS TABLE

Reference table indicates swage outer dimensions before and after swaging with the correct Die Set.

Wire Diameter	Before Swage O.D.	After Swage O.D.	Hole Diameter	Hole Depth (Rigging)	Hole Depth (Lifeline)
1/16"	0.218 - 0.213	0.190 - 0.185	0.078	7/8"	-
3/32"	0.218 - 0.213	0.190 - 0.185	0.109	1 1/4"	-
1/8"	0.250 - 0.245	0.219 - 0.214	0.141	1 1/2"	7/8"
5/32"	0.297 - 0.292	0.250 - 0.245	0.172	1 3/4"	1 1/8"
3/16"	0.359 - 0.354	0.313 - 0.308	0.203	2"	1 1/8"
7/32"	0.427 - 0.422	0.375 - 0.368	0.234	2 1/4"	-
*1/4"	0.494 - 0.489	0.438 - 0.431	0.265	2 1/2"	*1 5/8"
9/32"	0.563 - 0.558	0.500 - 0.492	0.297	2 3/4"	-
5/16"	0.635 - 0.630	0.563 - 0.554	0.328	3"	-
3/8"	0.703 - 0.698	0.625 - 0.618	0.390	3 1/2"	-
7/16"	0.781 - 0.773	0.688 - 0.680	0.453	4 1/2"	-
1/2"	0.844 - 0.839	0.750 - 0.741	0.531	5"	-
9/16"	0.984 - 0.979	0.875 - 0.866	0.593	5 1/2"	-
5/8"	1.109 - 1.104	1.000 - 0.990	0.656	6 1/4"	-
3/4"	1.359 - 1.354	1.250 - 1.238	0.781	7 1/2"	-
7/8"	1.593 - 1.583	1.437 - 1.425	0.933	9 5/8"	-
1"	1.812 - 1.802	1.625 - 1.613	1.062	11 1/2"	-

Wire Diameter	Before Swage O.D.	After Swage O.D.	Hole Diameter	Hole Depth (Rigging)	Hole Depth (Lifeline)
1.5 mm	0.218 - 0.213	0.190 - 0.185	-	7/8"	-
2.5 mm	0.218 - 0.213	0.190 - 0.185	0.109	1 1/4"	-
3 mm	0.250 - 0.245	0.219 - 0.214	0.132	1 1/2"	7/8"
4 mm	0.297 - 0.292	0.250 - 0.245	0.172	1 3/4"	1 1/8"
5 mm	0.359 - 0.354	0.313 - 0.308	0.210	2"	1 1/8"
5.5 mm	0.427 - 0.422	0.375 - 0.368	0.232	2 1/4"	-
*6 mm	0.494 - 0.489	0.438 - 0.431	0.252	2 1/2"	*1 5/8"
7 mm	0.563 - 0.558	0.500 - 0.492	0.297	2 3/4"	-
8 mm	0.635 - 0.630	0.563 - 0.554	0.328	3"	-
9-10 mm	0.703 - 0.698	0.625 - 0.618	0.413	3 1/2"	2"
11 mm	0.781 - 0.773	0.688 - 0.680	0.453	4 1/2"	-
12 mm	0.844 - 0.839	0.750 - 0.741	0.500	5"	-
14 mm	0.984 - 0.979	0.875 - 0.866	0.593	5 1/2"	-
16 mm	1.109 - 1.104	1.000 - 0.990	0.656	6 1/4"	-
19 mm	1.359 - 1.354	1.250 - 1.238	0.781	7 1/2"	-
22 mm	1.593 - 1.583	1.437 - 1.425	0.933	9 5/8"	-
26 mm	1.812 - 1.802	1.625 - 1.613	1.062	11 1/2"	-

*NOTE: 1/4" and 6mm lifeline fittings use 7/32" (5.5mm) swager dies and specifications.

up to 1" wire

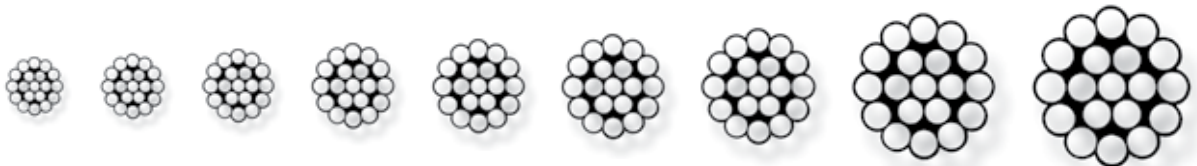

STAINLESS STEEL WIRE ROPE

Composed of high-tensile **ANSI 316** stainless steel that meets or exceeds BSMA 29 tolerances for nominal diameter, tensile strength, and break force thresholds. Wire rope conforms to ASTM A492 and FED-RR-W-410F.

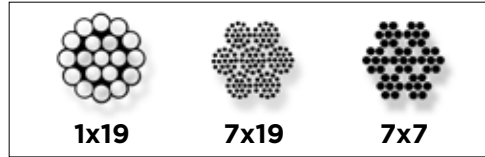

1x19 Stainless Steel Wire

Part #	Wire Diameter	Strand	Part #	Part #	Part #	Part #	Part #	N.B.S. lbs
SC06219	1/16"	1 x 19	SC0621925	SC0621950	SC062191M	-	SC062195M	445
SC09319	3/32"	1 x 19	SC0931925	SC0931950	-	-	-	1,068
SC12519	1/8"	1 x 19	SC1251925	SC1251950	SC125191M	SC125192M	SC125195M	1,869
SC15619	5/32"	1 x 19	SC1561925	SC1561950	SC156191M	SC156192M	SC156195M	2,937
SC18819	3/16"	1 x 19	SC1881925	SC1881950	SC188191M	SC188192M	SC188195M	4,183
SC21819	7/32"	1 x 19	SC2181925	SC2181950	SC218191M	-	-	5,607
SC25019	1/4"	1 x 19	SC2501925	SC2501950	SC250191M	-	SC250195M	7,298
SC28119	9/32"	1 x 19	SC2811925	SC2811950	SC281191M	-	-	9,261
SC31219	5/16"	1 x 19	SC3121925	SC3121950	-	-	-	11,125
SC37519	3/8"	1 x 19	SC3751925	SC3751950	-	-	-	15,575
SC43719	7/16"	1 x 19	SC4371925	SC4371950	-	-	-	20,025
SC50019	1/2"	1 x 19	SC5001925	SC5001950	-	-	-	25,116
SC56219	9/16"	1 x 19	-	-	-	-	-	28,649
SC62519	5/8"	1 x 19	-	-	-	-	-	45,194

7x19 & 7x7 Stainless Steel Wire

Part #	Wire Diameter	Strand	Part #	Part #	Part #	Part #	Part #	N.B.S. lbs
SC06279	1/16"	7 x 19	SC0627925	-	-	-	-	-
SC09379	3/32"	7 x 19	SC0937925	SC0937950	-	-	-	700
SC12579	1/8"	7 x 19	SC1257925	SC1257950	SC125791M	SC125792M	SC125795M	1,328
SC15679	5/32"	7 x 19	SC1567925	SC1567950	SC156791M	SC156792M	SC156795M	2,074
SC18879	3/16"	7 x 19	SC1887925	SC1887950	SC188791M	SC188792M	SC188795M	2,963
SC21879	7/32"	7 x 19	-	-	-	-	-	4,056
SC25079	1/4"	7 x 19	SC2507925	SC2507950	-	SC250792M	-	5,308
SC31279	5/16"	7 x 19	-	-	-	-	-	8,290
SC37579	3/8"	7 x 19	SC3757925	-	-	-	-	11,951
SC50079	1/2"	7 x 19	-	-	-	-	-	-
SC06277	1/16"	7 x 7	-	-	-	-	-	335
SC09377	3/32"	7 x 7	SC0937725	SC0937750	-	-	-	806
SC12577	1/8"	7 x 7	SC1257725	SC1257750	SC125771M	SC125772M	SC125775M	1,434
SC15677	5/32"	7 x 7	SC1567725	SC1567750	SC156771M	SC156772M	SC156775M	2,211
SC18877	3/16"	7 x 7	SC1887725	SC1887750	SC188771M	SC188772M	SC188775M	3,218
SC25077	1/4"	7 x 7	SC2507725	SC2507750	-	-	SC250775M	5,728
SC31277	5/16"	7 x 7	SC3127725	-	-	-	-	8,090
SC37577	3/8"	7 x 7	SC3757725	-	-	-	-	11,494

Vinyl Coated - 7x7 Stainless Steel Wire

Part #	Wire Diameter	Strand	Part #	Part #	Part #	Part #	Part #	N.B.S. lbs
LLC11618W	1/16" (1/8" White)	7 x 7	LLC11618W25	LLC11618W50	-	-	-	335
LLC332532W	3/32" (5/32" White)	7 x 7	LLC332532W25	LLC332532W50	-	-	-	806
LLC18732W	1/8" (7/32" White)	7 x 7	LLC18732W25	LLC18732W50	-	-	-	1,434
LLC18732C	1/8" (7/32" Clear)	7 x 7	-	-	-	-	-	1,434
LLC532732W	5/32" (7/32" White)	7 x 7	LLC532732W25	LLC532732W50	-	-	-	2,211
LLC316516W	3/16" (5/16" White)	7 x 7	LLC316516W25	LLC316516W50	-	-	-	3,218
LLC316516B	3/16" (5/16" Black)	7 x 7	-	-	-	-	-	3,218
LLC316516C	3/16" (5/16" Clear)	7 x 7	-	-	-	-	-	3,218
LLC1438W	1/4" (3/8" White)	7 x 7	LLC1438W25	LLC1438W50	-	-	-	5,728

STAINLESS STEEL WIRE ROPE (CONTINUED)



Metric 1x19 Stainless Steel Wire

Per Foot 316 SS



Part #	Wire Diameter	Strand	N.B.S. lbs
SCM0419	4mm	1 x 19	2,965
SCM0519	5mm	1 x 19	4,631
SCM0619	6mm	1 x 19	6,671
SCM0719	7mm	1 x 19	9,078
SCM0819	8mm	1 x 19	11,858
SCM1019	10mm	1 x 19	18,527
SCM1219	12mm	1 x 19	26,680
SCM1419	14mm	1 x 19	36,316
SCM1619	16mm	1 x 19	45,194

Compact Strand Stainless Steel Wire

Per Foot 316 SS



250' Spool

500' Spool

Part #	Wire Diameter	Strand	Part #	Part #	N.B.S. lbs
SCM0317CS	3mm	1 x 7	SCM0317CS25	SCM0317CS50	2,205
SCM0417CS	4mm	1 x 7	SCM0417CS25	SCM0417CS50	3,924
SCM0519CS	5mm	1 x 19	SCM0519CS25	SCM0519CS50	5,379
SCM0619CS	6mm	1 x 19	SCM0619CS25	SCM0619CS50	7,826
SCM0719CS	7mm	1 x 19	SCM0719CS25	SCM0719CS50	10,825
SCM0819CS	8mm	1 x 19	SCM0819CS25	SCM0819CS50	13,558
SCM1019CS	10mm	1 x 19	SCM1019CS25	SCM1019CS50	21,539
SCM1219CS	12mm	1 x 19	SCM1219CS25	SCM1219CS50	31,747
SCM1436CS	14mm	1 x 36	-	-	42,215
SCM1636CS	16mm	1 x 36	-	-	56,395
SCM1936CS	19mm	1 x 36	-	-	79,525

Manufacturer certifications available upon request.

N.B.S. - Nominal Break Strength / lbs

All Hayn **rigging hardware** is engineered to exceed the breaking strength of 1x19 ANSI 316 stainless steel wire rope in it's corresponding wire size. However, a maximum of 40% of the amounts listed in the above tables should not be exceeded. Consult your engineer for the applicable safe working load for your application.

All Hayn **lifeline hardware** is engineered to exceed the breaking strength of 7x7 ANSI 316 stainless steel wire rope in it's corresponding wire size. However, a maximum of 40% of the amounts listed in the above tables should not be exceeded. Consult your engineer for the applicable safe working load for your application.



SWAGE MARINE EYES

316 Stainless Steel

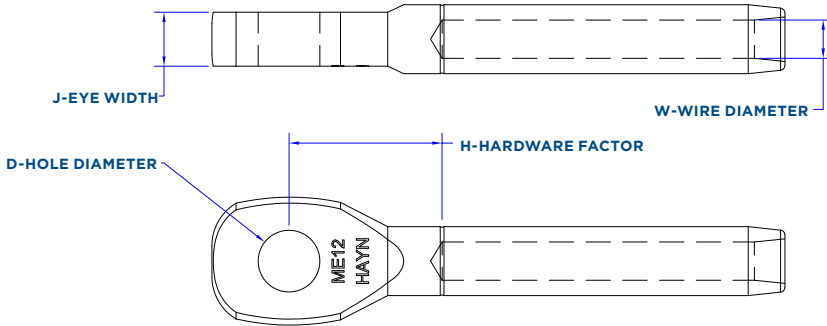

Imperial Wire Sizes

Part #	W-Wire Ø	D-Hole Ø	H-Hardware Factor	J-Eye Width	Weight lbs.
ME2	1/16"	1/4"	3/4"	7/32"	0.03
ME3	3/32"	1/4"	13/16"	7/32"	0.03
ME4	1/8"	1/4"	11/16"	7/32"	0.04
ME5A	5/32"	1/4"	11/16"	7/32"	0.04
ME5	5/32"	5/16"	13/16"	1/4"	0.05
ME6A	3/16"	5/16"	3/4"	1/4"	0.10
ME6	3/16"	3/8"	15/16"	5/16"	0.09
ME7DS	7/32"	3/8"	1 1/8"	3/8"	0.16
ME7	7/32"	7/16"	1 1/8"	3/8"	0.17
ME8A	1/4"	3/8"	7/8"	5/16"	0.19
ME8DS	1/4"	7/16"	1 5/32"	3/8"	0.24
ME8	1/4"	1/2"	1 1/8"	3/8"	0.22
ME9	9/32"	1/2"	1 3/32"	15/32"	0.28
ME10A	5/16"	1/2"	1 3/16"	1/2"	0.37
ME10	5/16"	5/8"	1 5/16"	1/2"	0.44
ME10B	5/16"	9/16"	1 3/16"	1/2"	0.41
ME12	3/8"	5/8"	1 9/16"	9/16"	0.57
ME14	7/16"	3/4"	1 15/16"	11/16"	0.99
ME16A	1/2"	3/4"	2 7/32"	11/16"	1.25
ME16	1/2"	7/8"	2 1/16"	7/8"	1.12
ME18	9/16"	7/8"	2 1/4"	13/16"	1.65
ME20	5/8"	1"	2 5/16"	15/16"	2.32
ME24	3/4"	1 1/8"	2 1/2"	1 1/32"	4.14
ME28	7/8"	1 1/4"	3 7/16"	1 3/16"	6.55
ME32	1"	1 3/8"	3 1/2"	1 3/8"	8.95

Metric Wire Sizes

Part #	W-Wire Ø	D-Hole Ø	H-Hardware Factor	J-Eye Width	Weight lbs.
MEM03	3mm	1/4"	11/16"	7/32"	0.03
MEM04	4mm	5/16"	13/16"	1/4"	0.05
MEM05	5mm	3/8"	15/16"	5/16"	0.09
MEM06A	6mm	3/8"	7/8"	5/16"	0.12
MEM06	6mm	1/2"	1 1/8"	3/8"	0.22
MEM07	7mm	1/2"	1 3/32"	15/32"	0.28
MEM08A	8mm	1/2"	1 3/16"	1/2"	0.44
MEM08	8mm	5/8"	1 5/16"	1/2"	0.37
MEM10	10mm	5/8"	1 9/16"	9/16"	0.57
MEM11	11mm	3/4"	1 15/16"	11/16"	0.99
MEM12	12mm	3/4"	2 7/32"	11/16"	1.12
MEM12US	12mm	7/8"	2 1/16"	7/8"	1.32
MEM14	14mm	7/8"	2 1/4"	13/16"	1.65
MEM16	16mm	1"	2 5/16"	15/16"	2.32
MEM19	19mm	1 1/8"	2 1/2"	1 1/32"	4.14
MEM22	22mm	1 1/4"	3 7/16"	1 3/16"	6.55
MEM26	26mm	1 3/8"	3 1/2"	1 3/8"	8.95

SWAGE RIGGING TOGGLES

316 Stainless Steel

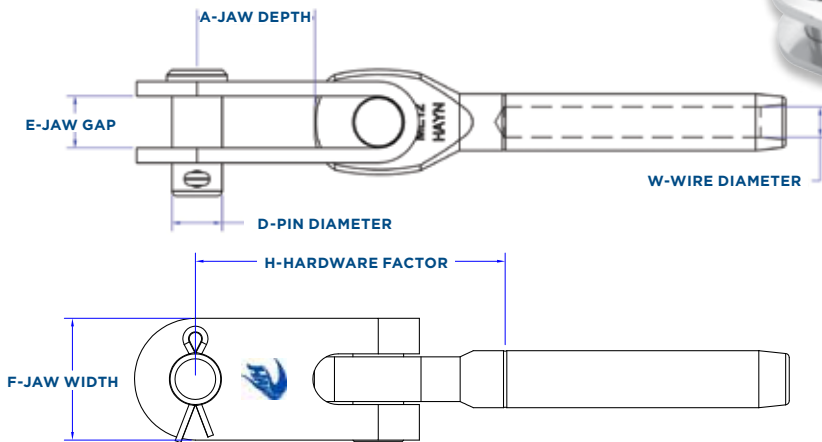

Imperial Wire Sizes

Part #	W-Wire Ø	D-Pin Ø	A-Jaw Depth	E-Jaw Gap	F-Jaw Width	H-Hardware Factor	Weight lbs.
14RT18	1/8"	1/4"	9/16"	1/4"	5/8"	1 5/8"	0.09
14RT532	5/32"	1/4"	9/16"	1/4"	5/8"	1 5/8"	0.12
516RT532	5/32"	5/16"	5/8"	5/16"	3/4"	1 3/4"	0.14
516RT316	3/16"	5/16"	19/32"	5/16"	3/4"	1 3/4"	0.17
38RT316	3/16"	3/8"	3/4"	3/8"	29/32"	2 5/32"	0.25
38RT732	7/32"	3/8"	11/16"	3/8"	29/32"	2 3/32"	0.36
38RT14	1/4"	3/8"	13/16"	3/8"	29/32"	2 3/32"	0.41
716RT14	1/4"	7/16"	1 1/8"	7/16"	1 1/16"	2 7/8"	0.54
716RT732	7/32"	7/16"	1 5/8"	7/16"	1 1/16"	2 7/8"	0.55
12RT14	1/4"	1/2"	1 1/16"	1/2"	1 5/32"	2 13/16"	0.56
12RT932	9/32"	1/2"	1 1/16"	1/2"	1 5/32"	2 3/4"	0.57
12RT516	5/16"	1/2"	1 1/16"	1/2"	1 5/32"	2 7/8"	0.66
58RT516	5/16"	5/8"	1 7/16"	5/8"	1 1/2"	3 9/16"	1.12
58RT38	3/8"	5/8"	1 7/16"	5/8"	1 1/2"	3 13/16"	1.25
34RT716	7/16"	3/4"	1 3/4"	3/4"	1 7/8"	4 5/8"	2.04
34RT12	1/2"	3/4"	1 3/4"	3/4"	1 7/8"	4 15/16"	2.17
78RT12	1/2"	7/8"	2 7/8"	7/8"	2 3/8"	6 1/32"	2.44
78RT916	9/16"	7/8"	2 31/32"	7/8"	2 3/8"	6 7/32"	3.93
1RT58	5/8"	1"	2 5/8"	1"	2 1/2"	6 1/8"	5.49
118RT34	3/4"	1 1/8"	2 3/4"	1 1/8"	2 3/4"	6 1/2"	9.04
114RT34	3/4"	1 1/4"	3 7/8"	1 1/4"	3 1/4"	8 7/8"	12.25
114RT78	7/8"	1 1/4"	3 7/8"	1 1/4"	3 1/4"	8 7/8"	13.77
138RT1	1"	1 3/8"	4 5/16"	1 3/8"	4"	9 7/16"	20.03

Metric Wire Sizes

Part #	W-Wire Ø	D-Pin Ø	A-Jaw Depth	E-Jaw Gap	F-Jaw Width	H-Hardware Factor	Weight lbs.
14RTM03	3mm	1/4"	9/16"	1/4"	5/8"	1 5/8"	0.09
516RTM04	4mm	5/16"	5/8"	5/16"	3/4"	1 3/4"	0.12
38RTM05	5mm	3/8"	3/4"	3/8"	29/32"	2 5/32"	0.24
38RTM06	6mm	3/8"	13/16"	3/8"	29/32"	2 3/32"	0.31
12RTM06	6mm	1/2"	1 1/16"	1/2"	1 5/32"	2 13/16"	0.57
12RTM07	7mm	1/2"	1 1/16"	1/2"	1 5/32"	2 3/4"	0.57
12RTM08	8mm	1/2"	1 1/16"	1/2"	1 5/32"	2 7/8"	0.72
58RTM08	8mm	5/8"	1 7/16"	5/8"	1 1/2"	3 9/16"	1.13
58RTM10	10mm	5/8"	1 7/16"	5/8"	1 1/2"	3 13/16"	1.09
34RTM11	11mm	3/4"	1 3/4"	3/4"	1 7/8"	4 5/8"	2.03
34RTM12	12mm	3/4"	1 3/4"	3/4"	1 7/8"	4 15/16"	2.22
78RTM12	12mm	7/8"	2 7/8"	7/8"	2 3/8"	6 1/32"	3.84
78RTM14	14mm	7/8"	2 31/32"	7/8"	2 3/8"	6 7/32"	4.35
1RTM16	16mm	1"	2 5/8"	1"	2 1/2"	6 1/8"	5.49
118RTM19	19mm	1 1/8"	2 3/4"	1 1/8"	2 3/4"	6 1/2"	9.04
114RTM19	19mm	1 1/4"	3 7/8"	1 1/4"	3 1/4"	8 7/8"	12.25
114RTM22	22mm	1 1/4"	3 7/8"	1 1/4"	3 1/4"	8 7/8"	13.77
138RTM26	26mm	1 3/8"	4 5/16"	1 3/8"	4"	9 7/16"	20.03

Increased jaw depths available. Call for details.

SWAGE RIGGING STUDS

316 Stainless Steel

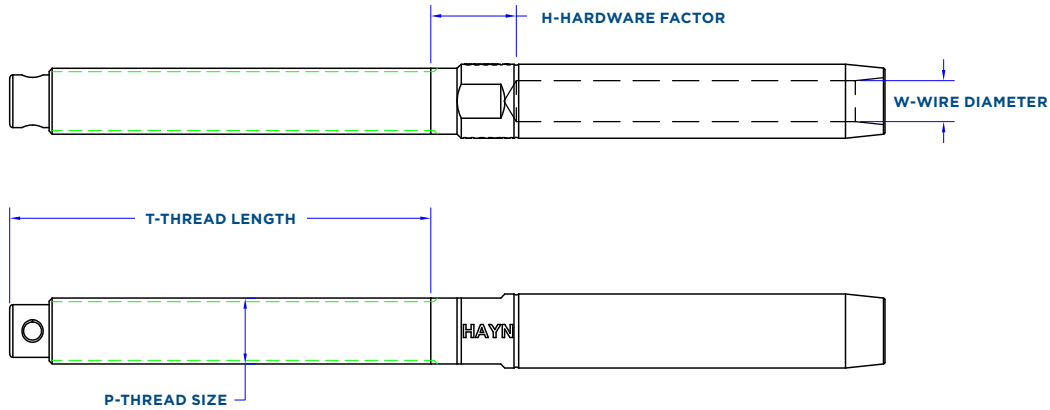

Right Hand Left Hand Imperial Thread, Machine Swage

Part #	Part #	W-Wire Ø	P-Thread	H-Hardware Factor	T-Thread Length	Weight lbs.
14SE332RH	14SE332LH	3/32"	1/4-28	1/2"	2 1/4"	0.04
14SE18RH	14SE18LH	1/8"	1/4-28	1/2"	2 1/4"	0.04
14ASE18RH	-	1/8"	1/4-28	1/2"	3"	0.05
14SE532RH	14SE532LH	5/32"	1/4-28	9/16"	2 1/4"	0.05
14ASE532RH	-	5/32"	1/4-28	3/4"	3"	0.06
516SE532RH	516SE532LH	5/32"	5/16-24	11/16"	2 3/8"	0.07
516SE316RH	516SE316LH	3/16"	5/16-24	3/4"	2 3/8"	0.09
38SE316RH	38SE316LH	3/16"	3/8-24	11/16"	2 7/8"	0.13
38SE732RH	38SE732LH	7/32"	3/8-24	11/16"	2 7/8"	0.16
716SE732RH	716SE732LH	7/32"	7/16-20	3/4"	2 3/4"	0.19
38SE14RH	38SE14LH	1/4"	3/8-24	3/4"	2 7/8"	0.20
716SE14RH	716SE14LH	1/4"	7/16-20	3/4"	2 3/4"	0.23
12SE14RH	12SE14LH	1/4"	1/2-20	3/4"	3 1/4"	0.28
716SE932RH	716SE932LH	9/32"	7/16-20	3/4"	2 3/4"	0.30
12SE932RH	12SE932LH	9/32"	1/2-20	3/4"	3 1/4"	0.33
12SE516RH	12SE516LH	5/16"	1/2-20	3/4"	3 1/4"	0.40
58SE516RH	58SE516LH	5/16"	5/8-18	3/4"	4"	0.55
916SE38RH	916SE38LH	3/8"	9/16-18	7/8"	4"	0.57
58SE38RH	58SE38LH	3/8"	5/8-18	3/4"	4"	0.64
34SE716RH	34SE716LH	7/16"	3/4-16	1"	5"	1.07
34SE12RH	34SE12LH	1/2"	3/4-16	1"	5"	1.16
78SE12RH	78SE12LH	1/2"	7/8-14	1 3/16"	6"	1.56
78SE916RH	78SE916LH	9/16"	7/8-14	1 1/4"	6"	1.90
1SE916RH	1SE916LH	9/16"	1-12	1 3/8"	6 1/4"	2.73
1SE58RH	1SE58LH	5/8"	1-12	1 5/16"	6 1/4"	2.69
118SE34RH	118SE34LH	3/4"	1 1/8-12	1 1/4"	7"	4.22
114SE78RH	114SE78LH	7/8"	1 1/4-12	1 1/2"	7 7/8"	6.86
138SE1RH	138SE1LH	1"	1 3/8-12	1 3/8"	8 5/8"	9.33

Custom configurations available upon request.



SWAGE RIGGING STUDS (CONTINUED)

316 Stainless Steel



Right Hand

Metric Wire Sizes, Machine Swage

Part #	W-Wire Ø	P-Thread	H-Hardware Factor	T-Thread Length	Weight lbs.
14SEM03RH	3mm	1/4-28	1/2"	2 1/4"	0.04
14SEM04RH	4mm	1/4-28	9/16"	2 1/4"	0.05
516SEM04RH	4mm	5/16-24	11/16"	2 3/8"	0.07
516SEM05RH	5mm	5/16-24	3/4"	2 3/8"	0.09
38SEM05RH	5mm	3/8-24	11/16"	2 7/8"	0.13
38SEM06RH	6mm	3/8-24	3/4"	2 7/8"	0.20
716SEM06RH	6mm	7/16-20	3/4"	2 3/4"	0.23
12SEM06RH	6mm	1/2-20	3/4"	3 1/4"	0.28
716SEM07RH	7mm	7/16-20	3/4"	2 3/4"	0.29
12SEM07RH	7mm	1/2-20	3/4"	3 1/4"	0.33
12SEM08RH	8mm	1/2-20	3/4"	3 1/4"	0.40
58SEM08RH	8mm	5/8-18	3/4"	4"	0.55
916SEM10RH	10mm	9/16-18	7/8"	4"	0.56
58SEM10RH	10mm	5/8-18	3/4"	4"	0.62
34SEM11RH	11mm	3/4-16	1"	5"	1.04
34SEM12RH	12mm	3/4-16	1"	5"	1.19
78SEM12RH	12mm	7/8-14	1 3/16"	6"	1.56
78SEM14RH	14mm	7/8-14	1 1/4"	6"	1.90
1SEM14RH	14mm	1-12	1 3/8"	6 1/4"	2.22
1SEM16RH	16mm	1-12	1 5/16"	6 1/4"	2.73
118SEM19RH	19mm	1 1/8-12	1 1/4"	7"	4.22
114SEM22RH	22mm	1 1/4-12	1 1/2"	7 7/8"	6.86
138SEM26RH	26mm	1 3/8-12	1 3/8"	8 5/8"	9.33

Right Hand

Extended Turnbuckle Studs, Machine Swage

Part #	W-Wire Ø	P-Thread	H-Hardware Factor	T-Thread Length	OAL Length	Weight lbs.
14SE532EX6R	5/32"	1/4-28	2 5/16"	2 1/4"	6"	0.08
516SE532EX7R	5/32"	5/16-24	2 15/16"	2 3/8"	7"	0.12
516SE316EX7R	3/16"	5/16-24	3 5/16"	2 3/8"	7 5/8"	0.17
38SE316EX8R	3/16"	3-8-24	3 1/8"	2 7/8"	8"	0.21
38SE732EX8R	7/32"	3/8-24	2 15/16"	2 7/8"	8"	0.25
38SE14EX8R	1/4"	3/8-24	2 5/8"	2 7/8"	8"	0.30
12SE14EX12R	1/4"	1/2-20	6 3/8"	3 1/4"	12"	0.59
12SE932EX12R	9/32"	1/2-20	6 5/16"	3 1/4"	12 1/4"	0.72
12SE516EX12R	5/16"	1/2-20	5 7/8"	3 1/4"	12"	0.86
58SE516EX12R	5/16"	5/8-18	5 1/16"	4"	12"	0.93
58SE38EX12R	3/8"	5/8-18	4 5/8"	4"	12"	1.05

SWAGE FORKS

316 Stainless Steel

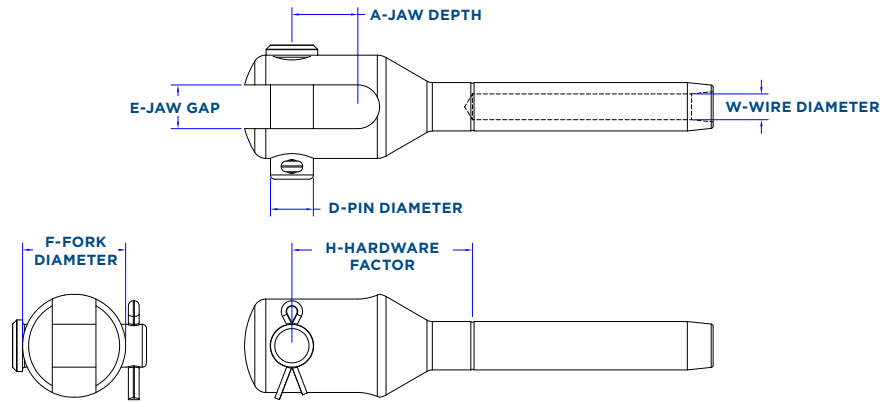

Imperial Wire Sizes

Part #	W-Wire Ø	D-Pin Ø	A-Jaw Depth	E-Jaw Gap	F-Fork Ø	H-Hardware Factor	Weight lbs.
SF04	1/8"	1/4"	3/8"	1/4"	9/16"	1"	0.05
SF05	5/32"	5/16"	7/16"	5/16"	11/16"	1 1/8"	0.09
SF06	3/16"	3/8"	9/16"	3/8"	7/8"	1 3/8"	0.18
SF08	1/4"	7/16"	11/16"	7/16"	1"	1 3/4"	0.31
SF08US	1/4"	1/2"	3/4"	1/2"	1 1/8"	1 13/16"	0.44
SF09	9/32"	1/2"	23/32"	1/2"	1 1/8"	1 11/16"	0.53
SF10DS	5/16"	1/2"	11/16"	1/2"	1 1/8"	1 13/16"	0.75
SF10	5/16"	9/16"	15/16"	9/16"	1 3/8"	2 1/16"	0.90
SF10US	5/16"	5/8"	15/16"	5/8"	1 1/2"	2 5/16"	1.09
SF12	3/8"	5/8"	15/16"	5/8"	1 1/2"	2 5/8"	1.98
SF16	1/2"	3/4"	1"	3/4"	1 7/8"	3"	2.71
SF18	9/16"	7/8"	1 5/16"	7/8"	2 1/8"	3 1/8"	3.60
SF20	5/8"	1"	1 15/32"	1"	2 1/2"	3 3/8"	5.35
SF24	3/4"	1 1/8"	1 3/4"	1 1/8"	2 3/4"	5 1/8"	7.84
SF28	7/8"	1 1/4"	1 15/16"	1 1/4"	3"	4 5/8"	9.62
SF32	1"	1 3/8"	2 1/8"	1 3/8"	3 1/4"	5 5/8"	12.20

Metric Wire Sizes

Part #	W-Wire Ø	D-Pin Ø	A-Jaw Depth	E-Jaw Gap	F-Fork Ø	H-Hardware Factor	Weight lbs.
SFM03	3mm	1/4"	3/8"	1/4"	9/16"	1"	0.05
SFM04	4mm	5/16"	7/16"	5/16"	11/16"	1 1/8"	0.09
SFM05	5mm	3/8"	9/16"	3/8"	7/8"	1 3/8"	0.18
SFM06	6mm	7/16"	11/16"	7/16"	1"	1 3/4"	0.32
SFM07	7mm	1/2"	23/32"	1/2"	1 1/8"	1 11/16"	0.44
SFM08DS	8mm	1/2"	11/16"	1/2"	1 1/8"	1 13/16"	0.53
SFM08	8mm	9/16"	15/16"	9/16"	1 3/8"	2 1/16"	0.75
SFM08US	8mm	5/8"	15/16"	5/8"	1 1/2"	2 5/16"	1.08
SFM10	10mm	5/8"	15/16"	5/8"	1 1/2"	2 5/8"	2.04
SFM12	12mm	3/4"	1"	3/4"	1 7/8"	3"	2.71
SFM14	14mm	7/8"	1 5/16"	7/8"	2 1/8"	3 1/8"	4.36
SFM16	16mm	1"	1 15/32"	1"	2 1/2"	3 3/8"	5.35
SFM19	19mm	1 1/8"	1 3/4"	1 1/8"	2 3/4"	5 1/8"	7.84
SFM22	22mm	1 1/4"	1 15/16"	1 1/4"	3"	4 5/8"	9.62
SFM26	26mm	1 3/8"	2 1/8"	1 3/8"	3 1/4"	5 5/8"	12.20

SWAGE AIRCRAFT EYES - MS STYLE

316 Stainless Steel

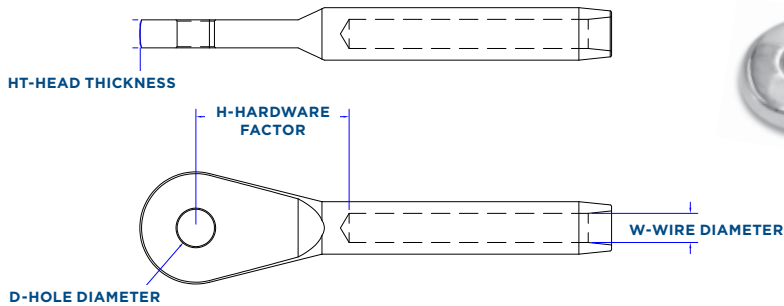

Part #	MS Style #	W-Wire Ø	D-Hole Ø	HT-Head Thickness	H-Hardware Factor	Weight lbs.
RE2	20668-2	1/16"	3/16"	3/32"	9/16"	0.01
RE3	20668-3	3/32"	3/16"	7/64"	13/16"	0.02
RE4	20668-4	1/8"	3/16"	3/16"	13/16"	0.03
RE5	20668-5	5/32"	1/4"	13/64"	15/16"	0.05
RE6	20668-6	3/16"	5/16"	1/4"	1"	0.09
RE7	20668-7	7/32"	5/16"	19/64"	1 1/8"	0.13
RE8	20668-8	1/4"	3/8"	5/16"	1 1/4"	0.19
RE9	20668-9	9/32"	7/16"	21/64"	1 3/8"	0.27
RE10	20668-10	5/16"	7/16"	11/32"	1 1/2"	0.38
RE12	20668-12	3/8"	1/2"	3/8"	2 1/16"	0.57
RE14	20668-14	7/16"	9/16"	3/8"	2 3/8"	0.77
RE16	20668-16	1/2"	5/8"	15/32"	2 5/8"	1.05

SWAGE AIRCRAFT FORKS - MS STYLE

316 Stainless Steel

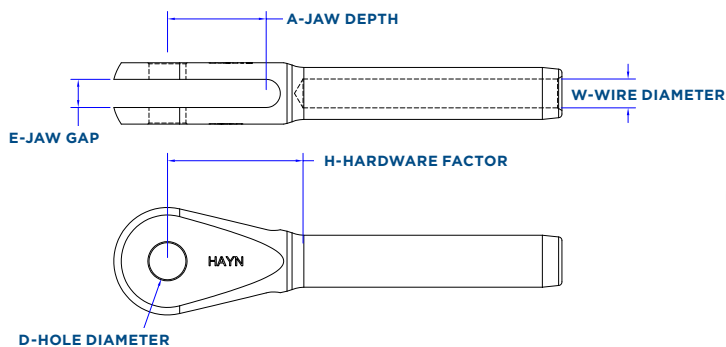

Part #	MS Style #	W-Wire Ø	D-Hole Ø	A-Jaw Depth	E-Jaw Gap	H-Hardware Factor	Weight lbs.
RF2	20667-2	1/16"	3/16"	7/16"	3/32"	11/16"	0.01
RF3	20667-3	3/32"	3/16"	5/8"	7/64"	11/16"	0.02
RF4	20667-4	1/8"	3/16"	11/16"	13/64"	7/8"	0.03
RF5	20667-5	5/32"	1/4"	11/16"	13/64"	15/16"	0.06
RF6	20667-6	3/16"	5/16"	3/4"	1/4"	1 1/16"	0.09
RF7	20667-7	7/32"	5/16"	13/16"	5/16"	1 3/16"	0.14
RF8	20667-8	1/4"	3/8"	7/8"	5/16"	1 5/16"	0.20
RF9	20667-9	9/32"	7/16"	1"	21/64"	1 3/8"	0.29
RF10	20667-10	5/16"	7/16"	1 3/32"	11/32"	1 7/16"	0.40
RF12	20667-12	3/8"	1/2"	1 5/16"	3/8"	1 13/16"	0.57
RF14	20667-14	7/16"	9/16"	1 9/16"	3/8"	1 7/8"	0.78
RF16	20667-16	1/2"	5/8"	1 11/16"	15/32"	2 1/16"	1.02

SWAGE STEMBALL TERMINALS

316 Stainless Steel

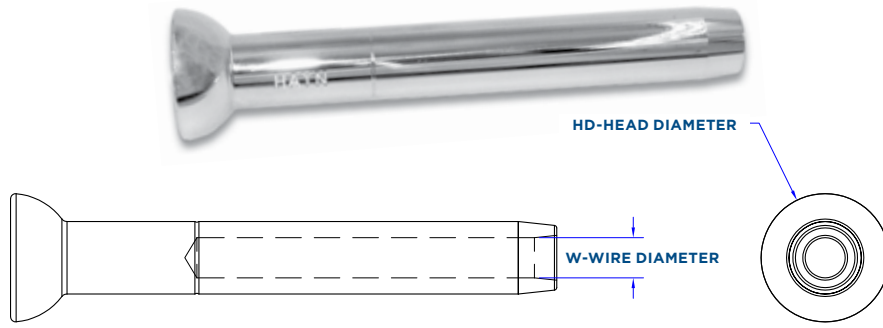

Imperial Wire Sizes

Part #	W-Wire Ø	Cup Washer #	HD-Head Ø	RAD-Radius	Weight lbs.
SB18	1/8"	SBC18	0.50"	0.25"	0.02
SB532	5/32"	SBC532	0.68"	0.34"	0.05
SB532X0.64	5/32"	SBC532	0.64"	0.34"	0.05
SB316	3/16"	SBC316	0.68"	0.34"	0.07
SB316X0.74	3/16"	SBC316	0.74"	0.37"	0.08
SB732	7/32"	SBC732	0.74"	0.40"	0.11
SB14	1/4"	SBC14	0.80"	0.40"	0.17
SB932	9/32"	SBC932	0.87"	0.42"	0.26
SB932X0.98	9/32"	-	0.98"	0.49"	0.28
SB516	5/16"	-	1.07"	0.54"	0.36
SB516X0.98	5/16"	SBC516	0.98"	0.49"	0.34
SB38	3/8"	-	1.24"	0.62"	0.54
SB38X1.09	3/8"	SBC38	1.09"	0.54"	0.50
SB716	7/16"	-	1.24"	0.62"	0.70
SB716X1.07	7/16"	SBC38	1.07"	0.53"	0.67
SB12	1/2"	-	1.38"	0.69"	0.87
SB916	9/16"	-	1.70"	0.86"	1.44

Metric Wire Sizes

Part #	W-Wire Ø	Cup Washer #	HD-Head Ø	RAD-Radius	Weight lbs.
SBM03	3mm	SBC18	12.6mm	6.3mm	0.02
SBM04	4mm	SBC532	17.5mm	8.8mm	0.05
SBM04X15	4mm	SBC532	16.2mm	8.8mm	0.07
SBM05	5mm	SBC316	17.2mm	8.6mm	0.08
SBM06	6mm	SBC14	20.6mm	10.3mm	0.17
SBM07	7mm	SBC932	21.6mm	22.0mm	0.26
SBM07X25	7mm	-	25mm	12.4mm	0.28
SBM08	8mm	-	27.2mm	13.8mm	0.36
SBM08X25	8mm	SBC516	25.0mm	12.4mm	0.34
SBM10	10mm	-	31.5mm	15.8mm	0.54
SBM10X27.5	10mm	SBC38	27.5mm	13.8mm	0.50
SBM11	11mm	-	31.5mm	15.7mm	0.70
SBM11X27	11mm	SBC38	27mm	13.4mm	0.67
SBM12	12mm	-	35mm	17.5mm	0.87
SBM12X32	12mm	-	32mm	16.0mm	0.79
SBM14	14mm	-	43mm	21.8mm	1.44

*NOTE: Due the numerous variations in Stemball configurations on the market, custom configurations are available to your specifications. Call for pricing and lead-times.

STEMBALL CUP WASHERS

316 Stainless Steel

Part #	D-Hole Ø	OD-Outside Ø	Weight lbs.
SBC18	0.35"	1.02"	0.02
SBC532	0.35"	1.02"	0.02
SBC316	0.43"	1.02"	0.02
SBC732	0.52"	1.02"	0.02
SBC14	0.64"	1.02"	0.02
SBC932	0.64"	1.02"	0.02
SBC516	0.79"	1.34"	0.03
SBC38	0.79"	1.34"	0.03

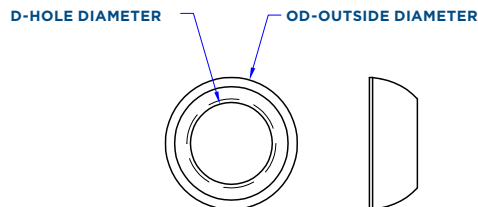

SWAGE "T" TERMINALS

316 Stainless Steel

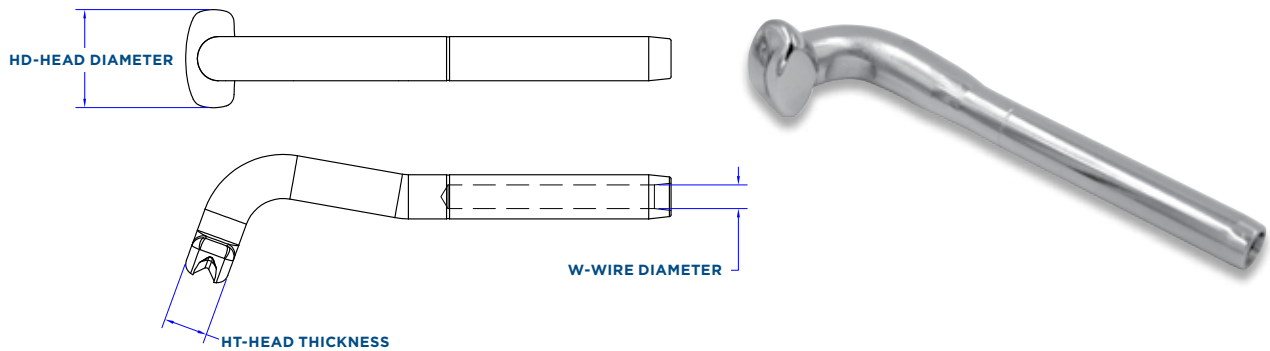

Imperial Wire Sizes

Part #	W-Wire Ø	HT-Head Thickness	HD - Head Ø	Weight lbs.
HYN-TB18	1/8"	0.25"	0.65"	0.04
HYN-TB532	5/32"	0.35"	0.69"	0.07
HYN-TB316	3/16"	0.35"	0.69"	0.11
HYN-TB732	7/32"	0.56"	1.10"	0.27
HYN-TB14	1/4"	0.56"	1.10"	0.42
HYN-TB932	9/32"	0.56"	1.10"	0.61
HYN-TB516	5/16"	0.70"	1.26"	0.82
HYN-TB38	3/8"	0.70"	1.26"	1.46

Metric Wire Sizes

Part #	W-Wire Ø	HT-Head Thickness	HD - Head Ø	Weight lbs.
HYN-TBM03	3mm	0.25"	0.65"	0.04
HYN-TBM04	4mm	0.35"	0.69"	0.07
HYN-TBM05	5mm	0.35"	0.69"	0.11
HYN-TBM06	6mm	0.56"	1.10"	0.42
HYN-TBM07	7mm	0.56"	1.10"	0.61
HYN-TBM08	8mm	0.70"	1.26"	0.82
HYN-TBM10	10mm	0.70"	1.26"	1.46

"T" TERMINAL BACKING PLATES

316 Stainless Steel

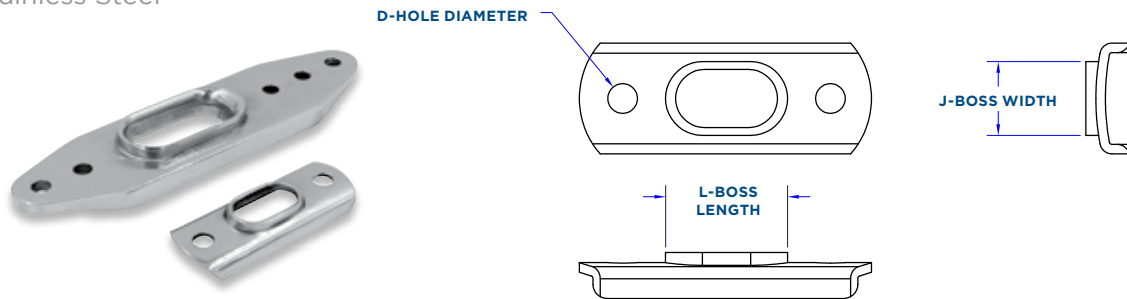

Part #	Terminal Wire Size	D-Hole Ø	J-Width	L-Length	Weight lbs.
SHBPM03	1/8" - 3mm	3/16"	0.40"	0.60"	0.02
SHBPM04	5/32" - 4mm	3/16"	0.56"	1.16"	0.07
SHBPM05	3/16" - 5mm	1/4"	0.65"	1.10"	0.05
SHBPM07	7/32" - 1/4" - 9/32" - 6mm - 7mm	1/4"	0.88"	1.55"	0.21
SHBPM10	5/16" - 3/8" - 8mm - 10mm	1/4"	1.0"	1.98"	0.49

"T" TERMINAL BACKING PLATE RUBBER PLUGS

Part #	Terminal Wire Size	L - Length	HT - Head Thickness	Weight lbs.
SHRPM03	1/8" - 3mm	7/32"	1/4"	0.001
SHRPM04	5/32" - 4mm	5/8"	3/8"	0.01
SHRPM05	3/16" - 5mm	1/2"	1/2"	0.01
SHRPM07	1/4" - 9/32" - 6mm - 7mm	3/4"	5/8"	0.02
SHRPM10	5/16" - 3/8" - 8mm - 10mm	3/4"	5/8"	0.02

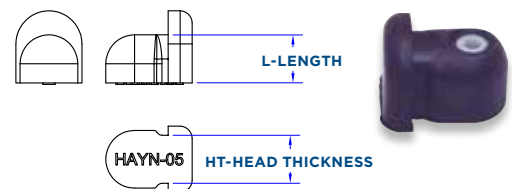

SWAGE SHROUD TERMINALS

316 Stainless Steel

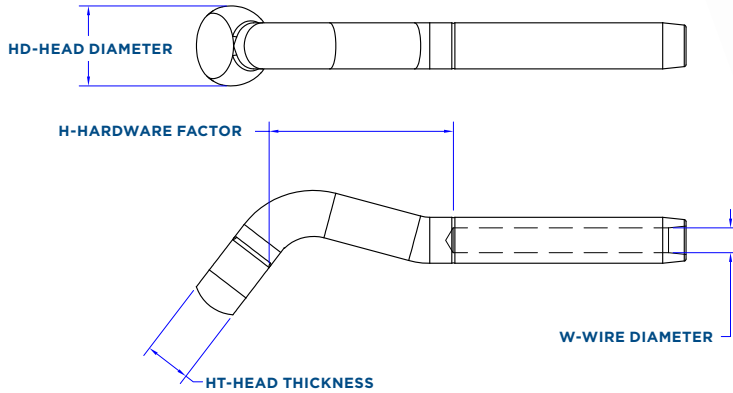

Imperial Wire Sizes

Part #	W-Wire Ø	HD-Head Ø	HT-Head Thickness	H-Hardware Factor	Weight lbs.
SH18	1/8"	0.47"	0.25"	1 3/16"	0.04
SH532	5/32"	0.63"	0.31"	1 3/8"	0.07
SH316	3/16"	0.74"	0.37"	1 1/2"	0.11
SH732	7/32"	0.74"	0.46"	1 3/4"	0.15
SH14	1/4"	0.86"	0.49"	1 7/8"	0.27
SH932	9/32"	1.10"	0.56"	2 1/4"	0.42
SH516	5/16"	1.18"	0.63"	2 1/2"	0.61
SH38	3/8"	1.26"	0.70"	2 3/4"	0.82
SH12	1/2"	1.49"	0.94"	3 1/2"	1.46

Metric Wire Sizes

Part #	W-Wire Ø	HD-Head Ø	HT-Head Thickness	H-Hardware Factor	Weight lbs.
SHM03	3mm	0.47"	0.25"	1 3/16"	0.04
SHM04	4mm	0.63"	0.31"	1 3/8"	0.07
SHM05	5mm	0.74"	0.37"	1 1/2"	0.11
SHM06	6mm	0.86"	0.49"	1 7/8"	0.27
SHM07	7mm	1.10"	0.56"	2 1/4"	0.42
SHM08	8mm	1.18"	0.63"	2 1/2"	0.61
SHM10	10mm	1.26"	0.70"	2 3/4"	0.83
SHM12	12mm	1.49"	0.94"	3 1/2"	1.43

SHROUD TERMINAL BACKING PLATES

316 Stainless Steel

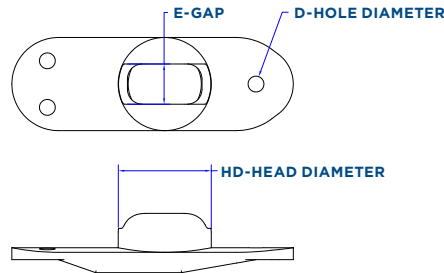

Part #	Terminal Wire Size	D-Hole Ø	HD-Head Ø	E-Gap	Weight lbs.
SHBPCM06	7/32" - 1/4" - 6mm	1/4"	1 1/4"	9/16"	0.12
SHBPCM07	9/32" - 7mm	1/4"	1 5/8"	11/16"	0.27
SHBPCM08	5/16" - 8mm	1/4"	1 5/8"	11/16"	0.39
SHBPCM10	3/8" - 10mm	1/4"	1 3/4"	13/16"	0.66
SHBPCM12	7/16" - 1/2" - 12mm	1/4"	2"	7/8"	1.02

*NOTE: Use "T" terminal backing plates for sizes below 1/4" (6mm). See page 17.

SHROUD TERMINAL BACKING PLATE RUBBER PLUGS

Part #	Terminal Wire Size	A-Jaw Depth	F-Jaw Width	Weight lbs.
SHRPCM06	1/4" - 6mm	1/4"	17/32"	0.01
SHRPCM07	9/32" - 7mm	3/8"	13/16"	0.02
SHRPCM08	5/16" - 8mm	3/8"	13/16"	0.02
SHRPCM10	3/8" - 10mm	25/64"	13/16"	0.02
SHRPCM12	7/16" - 1/2" - 12mm	17/32"	1"	0.03

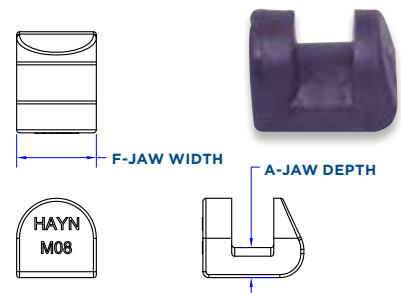

SWAGE RIGGING ADJUSTERS

316 Stainless Steel

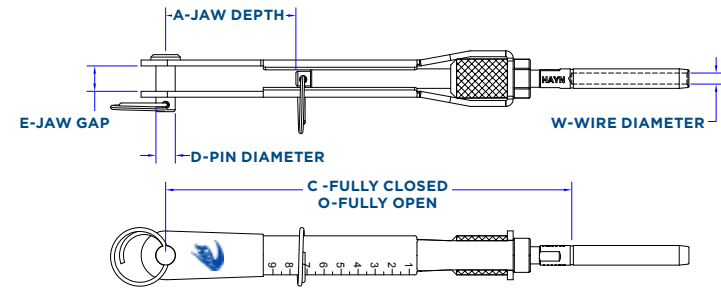

Long Rigging Adjuster

Part #	W-Wire Ø	D-Pin Ø	O-Open L	C-Closed L	A-Jaw Depth	E-Jaw Gap	Weight lbs.
10SA332	3/32"	3/16"	7 1/8"	5 1/8"	1 1/4" min.	5/16"	0.18
10SA18	1/8"	3/16"	7 1/8"	5 1/8"	1 1/4" min.	5/16"	0.19
14SA18	1/8"	1/4"	7 3/8"	5 1/4"	1 5/16" min.	5/16"	0.20
14SA532	5/32"	1/4"	7 3/8"	5 1/4"	1 5/16" min.	5/16"	0.21

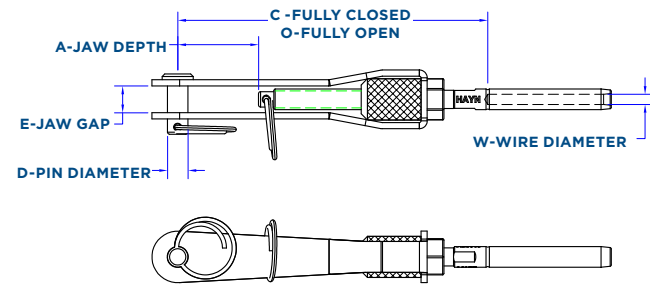

Short Rigging Adjuster

Part #	W-Wire Ø	D-Pin Ø	O-Open L	C-Closed L	A-Jaw Depth	E-Jaw Gap	Weight lbs.
14AR332	3/32"	1/4"	4 3/4"	3 3/4"	1" min.	5/16"	0.15
14AR18	1/8"	1/4"	4 3/4"	3 3/4"	31/32" min.	5/16"	0.18



TURNBUCKLES

- 21** Toggle Jaw To Swage - Open Body
- 22** Eye Toggle Jaw To Swage - Open Body
- 24** Fork and Open Body / Stemball and Open Body
- 25** Toggle Jaw To Toggle Jaw - Open Body
- 26** Eye to Swage - Open Body
- 27** Toggle Jaws And Open Body
- 28** Toggle Jaws And Closed Body
- 29** Eye Toggle Jaw To Swage - Closed Body
- 30** Toggle Jaw To Swage - Closed Body
- 31** Toggle Jaws To Toggle Jaws - Closed Body
- 32** Eye To Swage - Closed Body
- 33** Turnbuckle Bodies



TOGGLE JAW TO SWAGE - OPEN BODY

316 Stainless Steel / Chromed Bronze Turnbuckle Body

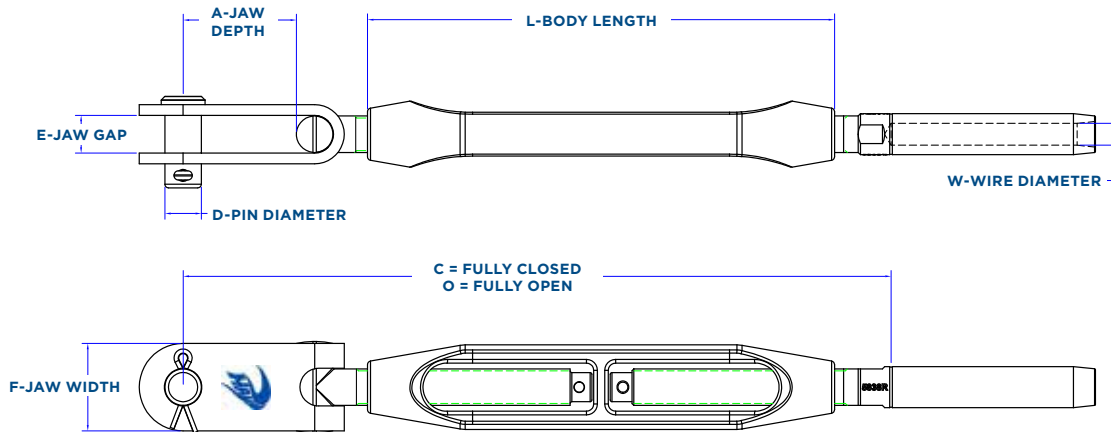

SMART PART # KEY toggle pin size | Toggle Forged Bronze Swage | wire size

Imperial Wire Sizes

Part #	W-Wire Ø	Thread	D-Pin Ø	O-Open L	C-Closed L	L-Body	A-Jaw Depth	E-Jaw Gap	F-Jaw Width	Weight lbs.
14TFBS332	3/32"	1/4-28	1/4"	9 3/4"	6 3/4"	4 1/2"	3/4"	1/4"	5/8"	0.24
14TFBS18	1/8"	1/4-28	1/4"	9 3/4"	6 3/4"	4 1/2"	3/4"	1/4"	5/8"	0.25
14TFBS532	5/32"	1/4-28	1/4"	9 3/4"	6 3/4"	4 1/2"	3/4"	1/4"	5/8"	0.26
516TFBS532	5/32"	5/16-24	5/16"	10 9/16"	7 5/16"	5"	13/16"	5/16"	3/4"	0.40
516TFBS316	3/16"	5/16-24	5/16"	10 5/8"	7 3/8"	5"	13/16"	5/16"	3/4"	0.43
38TFBS316	3/16"	3/8-24	3/8"	11 3/4"	8 1/4"	5 1/2"	1"	3/8"	7/8"	0.63
38TFBS732	7/32"	3/8-24	3/8"	11 13/16"	8 5/16"	5 1/2"	1"	3/8"	7/8"	0.65
38TFBS14	1/4"	3/8-24	3/8"	11 7/8"	8 3/8"	5 1/2"	1"	3/8"	7/8"	0.70
12TFBS14	1/4"	1/2-20	1/2"	1'-1 7/8"	9 7/8"	6 1/2"	1 7/16"	1/2"	1 5/32"	1.42
12TFBS932	9/32"	1/2-20	1/2"	1'-1 7/8"	9 7/8"	6 1/2"	1 7/16"	1/2"	1 5/32"	1.47
12TFBS516	5/16"	1/2-20	1/2"	1'-1 7/8"	9 7/8"	6 1/2"	1 7/16"	1/2"	1 5/32"	1.54
58TFBS516	5/16"	5/8-18	5/8"	1'-5 1/8"	1'-0 1/8"	8"	1 15/16"	5/8"	1 1/2"	2.63
58TFBS38	3/8"	5/8-18	5/8"	1'-5 1/8"	1'-0 1/8"	8"	1 15/16"	5/8"	1 1/2"	2.72
34TFBS716	7/16"	3/4-16	3/4"	1'-9 5/8"	1'-3 5/8"	10"	2 5/16"	3/4"	1 7/8"	5.00
34TFBS12	1/2"	3/4-16	3/4"	1'-9 5/8"	1'-3 5/8"	10"	2 5/16"	3/4"	1 7/8"	5.09

Metric Wire Sizes

Part #	W-Wire Ø	Thread	D-Pin Ø	O-Open L	C-Closed L	L-Body	A-Jaw Depth	E-Jaw Gap	F-Jaw Width	Weight lbs.
14TFBSM03	3mm	1/4-28	1/4"	9 3/4"	6 3/4"	4 1/2"	3/4"	1/4"	5/8"	0.25
14TFBSM04	4mm	1/4-28	1/4"	9 3/4"	6 3/4"	4 1/2"	3/4"	1/4"	5/8"	0.26
516TFBSM04	4mm	5/16-24	5/16"	10 9/16"	7 5/16"	5"	13/16"	5/16"	3/4"	0.41
516TFBSM05	5mm	5/16-24	5/16"	10 5/8"	7 3/8"	5"	13/16"	5/16"	3/4"	0.43
38TFBSM05	5mm	3/8-24	3/8"	11 13/16"	8 5/16"	5 1/2"	1"	3/8"	7/8"	0.62
38TFBSM06	6mm	3/8-24	3/8"	11 7/8"	8 3/8"	5 1/2"	1"	3/8"	7/8"	0.70
12TFBSM06	6mm	1/2-20	1/2"	1'-1 7/8"	9 7/8"	6 1/2"	1 7/16"	1/2"	1 5/32"	1.42
12TFBSM07	7mm	1/2-20	1/2"	1'-1 7/8"	9 7/8"	6 1/2"	1 7/16"	1/2"	1 5/32"	1.47
12TFBSM08	8mm	1/2-20	1/2"	1'-1 7/8"	9 7/8"	6 1/2"	1 7/16"	1/2"	1 5/32"	1.56
58TFBSM08	8mm	5/8-18	5/8"	1'-5 1/8"	1'-0 1/8"	8"	1 15/16"	5/8"	1 1/2"	2.63
58TFBSM10	10mm	5/8-18	5/8"	1'-5 1/8"	1'-0 1/8"	8"	1 15/16"	5/8"	1 1/2"	2.70
34TFBSM11	11mm	3/4-16	3/4"	1'-9 5/8"	1'-3 5/8"	10"	2 15/16"	3/4"	1 7/8"	5.00
34TFBSM12	12mm	3/4-16	3/4"	1'-9 5/8"	1'-3 5/8"	10"	2 15/16"	3/4"	1 7/8"	5.14

EYE TOGGLE JAW TO SWAGE - OPEN BODY

316 Stainless Steel / Chromed Bronze Turnbuckle Body

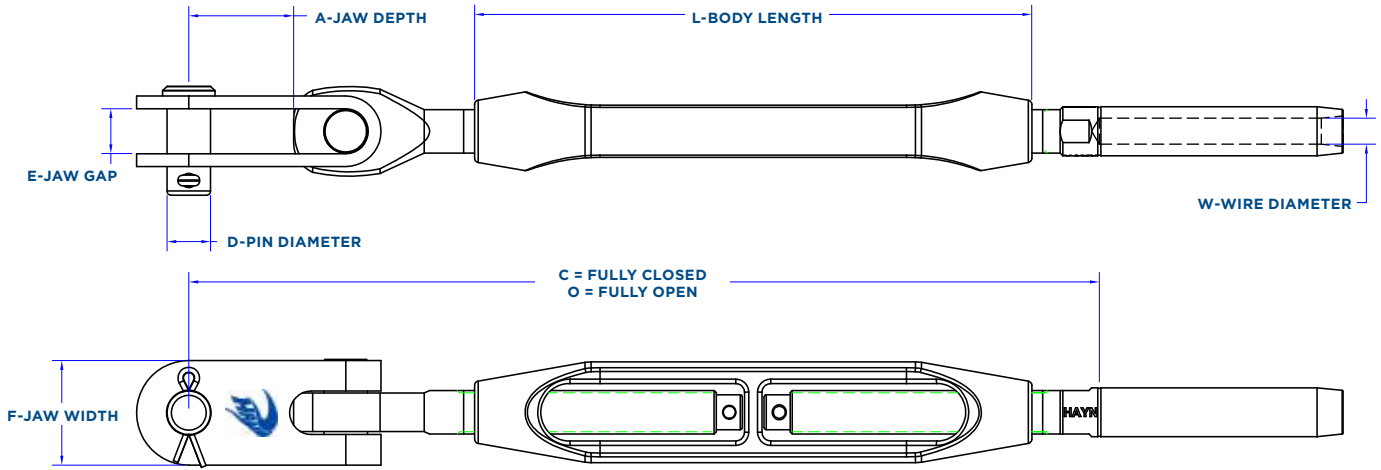

SMART PART # KEY toggle pin size | **Eye Toggle Forged Bronze** | wire size
Imperial Wire Sizes

Part #	W-Wire Ø	Thread	D-Pin Ø	O-Open L	C-Closed L	L-Body	A-Jaw Depth	E-Jaw Gap	F-Jaw Width	Weight lbs.
14ETFB332	3/32"	1/4-28	1/4"	9 11/16"	6 11/16"	4 1/2"	9/16"	1/4"	5/8"	0.25
14ETFB18	1/8"	1/4-28	1/4"	9 11/16"	6 11/16"	4 1/2"	9/16"	1/4"	5/8"	0.26
14ETFB532	5/32"	1/4-28	1/4"	9 3/4"	6 3/4"	4 1/2"	9/16"	1/4"	5/8"	0.27
516ETFB532	5/32"	5/16-24	5/16"	10 3/4"	7 1/2"	5"	5/8"	5/16"	3/4"	0.43
516ETFB316	3/16"	5/16-24	5/16"	10 13/16"	7 9/16"	5"	5/8"	5/16"	3/4"	0.45
38ETFB316	3/16"	3/8-24	3/8"	12 3/16"	8 11/16"	5 1/2"	3/4"	3/8"	7/8"	0.67
38ETFB732	7/32"	3/8-24	3/8"	12 3/16"	8 11/16"	5 1/2"	3/4"	3/8"	7/8"	0.70
38ETFB14	1/4"	3/8-24	3/8"	12 1/4"	8 3/4"	5 1/2"	3/4"	3/8"	7/8"	0.75
716ETFB14	1/4"	7/16-20	7/16"	1'-1 3/16"	9 11/16"	5 7/8"	1 1/4"	7/16"	1 1/16"	1.15
12ETFB14	1/4"	1/2-20	1/2"	1'-2 5/8"	10 5/8"	6 1/2"	1 1/8"	1/2"	1 5/32"	1.53
12ETFB932	9/32"	1/2-20	1/2"	1'-2 5/8"	10 5/8"	6 1/2"	1 1/8"	1/2"	1 5/32"	1.59
12ETFB516	5/16"	1/2-20	1/2"	1'-2 5/8"	10 5/8"	6 1/2"	1 1/8"	1/2"	1 5/32"	1.67
58ETFB516	5/16"	5/8-18	5/8"	1'-6 1/16"	1'-1 1/16"	8"	1 1/2"	5/8"	1 1/2"	2.71
58ETFB38	3/8"	5/8-18	5/8"	1'-6 1/16"	1'-1 1/16"	8"	1 1/2"	5/8"	1 1/2"	2.80
34ETFB716	7/16"	3/4-16	3/4"	1'-10"	1'-4"	10"	1 7/8"	3/4"	1 7/8"	5.36
34ETFB12	1/2"	3/4-16	3/4"	1'-10"	1'-4"	10"	1 7/8"	3/4"	1 7/8"	5.44
78ETFB12	1/2"	7/8-14	7/8"	2'-3 3/8"	1'-7 7/8"	1'-0 7/16"	2 7/8"	7/8"	2 3/8"	9.21
78ETFB916	9/16"	7/8-14	7/8"	2'-3 9/16"	1'-8 1/16"	1'-0 7/16"	2 7/8"	7/8"	2 3/8"	9.35
1ETFB916	9/16"	1-12	1"	2'-6 5/16"	1'-9 5/16"	1'-2 3/16"	2 5/8"	1"	2 1/2"	12.65
1ETFB58	5/8"	1-12	1"	2'-6 1/8"	1'-9 1/8"	1'-2 3/16"	2 5/8"	1"	2 1/2"	13.10
118ETFB34	3/4"	1 1/8-12	1 1/8"	2'-9 1/4"	1'-11 3/4"	1'-4"	2 3/4"	1 1/8"	2 3/4"	19.71
114ETFB34	3/4"	1 1/4-12	1 1/8"	3'-2 1/4"	2'-3 3/4"	1'-5 7/8"	3 7/8"	1 1/4"	3 1/4"	25.35
114ETFB78	7/8"	1 1/4-12	1 1/4"	3'-2 1/4"	2'-3 3/4"	1'-5 7/8"	3 7/8"	1 1/4"	3 1/4"	26.46
138ETFB1	1"	1 3/8-12	1 3/8"	3'-5 5/16"	2'-5 5/16"	1'-7 1/2"	4 5/16"	1 3/8"	4"	39.24



EYE TOGGLE JAW TO SWAGE (CONTINUED)

316 Stainless Steel / Chromed Bronze Turnbuckle Body



Metric Wire Sizes

Part #	W-Wire Ø	Thread	D-Pin Ø	O-Open L	C-Closed L	L-Body	A-Jaw Depth	E-Jaw Gap	F-Jaw Width	Weight lbs.
14ETFBM03	3mm	1/4-28	1/4"	9 11/16"	6 11/16"	4 1/2"	9/16"	1/4"	5/8"	0.25
14ETFBM04	4mm	1/4-28	1/4"	9 3/4"	6 3/4"	4 1/2"	9/16"	1/4"	5/8"	0.27
516ETFBM04	4mm	5/16-24	5/16"	10 3/4"	7 1/2"	5"	5/8"	5/16"	3/4"	0.43
516ETFBM05	5mm	5/16-24	5/16"	10 13/16"	7 9/16"	5"	5/8"	5/16"	3/4"	0.45
38ETFBM05	5mm	3/8-24	3/8"	12 3/16"	8 11/16"	5 1/2"	3/4"	3/8"	7/8"	0.67
38ETFBM06	6mm	3/8-24	3/8"	12 1/4"	8 3/4"	5 1/2"	3/4"	3/8"	7/8"	0.75
12ETFBM06	6mm	1/2-20	1/2"	1'-2 5/8"	10 5/8"	6 1/2"	1 1/8"	1/2"	1 5/32"	1.54
12ETFBM07	7mm	1/2-20	1/2"	1'-2 5/8"	10 5/8"	6 1/2"	1 1/8"	1/2"	1 5/32"	1.59
12ETFBM08	8mm	1/2-20	1/2"	1'-2 5/8"	10 5/8"	6 1/2"	1 1/8"	1/2"	1 5/32"	1.65
58ETFBM08	8mm	5/8-18	5/8"	1'-6 1/16"	1'-1 1/16"	8"	1 1/2"	5/8"	1 1/2"	2.71
58ETFBM10	10mm	5/8-18	5/8"	1'-6 1/16"	1'-1 1/16"	8"	1 1/2"	5/8"	1 1/2"	2.78
34ETFBM11	11mm	3/4-16	3/4"	1'-10"	1'-4"	10"	1 7/8"	3/4"	1 7/8"	5.31
34ETFBM12	12mm	3/4-16	3/4"	1'-10"	1'-4"	10"	1 7/8"	3/4"	1 7/8"	5.46
78ETFBM12	12mm	7/8-14	7/8"	2'-3 3/8"	1'-7 7/8"	1'-0 7/16"	2 7/8"	7/8"	2 3/8"	9.25
78ETFBM14	14mm	7/8-14	7/8"	2'-3 9/16"	1'-8 1/16"	1'-0 7/16"	2 7/8"	7/8"	2 3/8"	9.35
1ETFBM14	14mm	1-12	1"	2'-6 5/16"	1'-9 5/16"	1'-2 3/16"	2 5/8"	1"	2 1/2"	12.65
1ETFBM16	16mm	1-12	1"	2'-6 1/8"	1'-9 1/8"	1'-2 3/16"	2 5/8"	1"	2 1/2"	13.10
118ETFBM19	19mm	1 1/8-12	1 1/8"	2'-9 1/4"	1'-11 3/4"	1'-4"	2 3/4"	1 1/8"	2 3/4"	19.71
114ETFBM19	19mm	1 1/4-12	1 1/4"	3'-2 1/4"	2'-3 3/4"	1'-5 7/8"	3 7/8"	1 1/4"	3 7/8"	25.35
114ETFBM22	22mm	1 1/4-12	1 1/4"	3'-2 1/4"	2'-3 3/4"	1'-5 7/8"	3 7/8"	1 1/4"	3 7/8"	26.46
138ETFBM26	26mm	1 3/8-12	1 3/8"	3'-5 5/16"	2'-5 5/16"	1'-7 1/2"	4 5/16"	1 3/8"	4"	39.24

Increased jaw depths available. Call for details.



FORK AND OPEN BODY

316 Stainless Steel / Chromed Bronze Turnbuckle Body

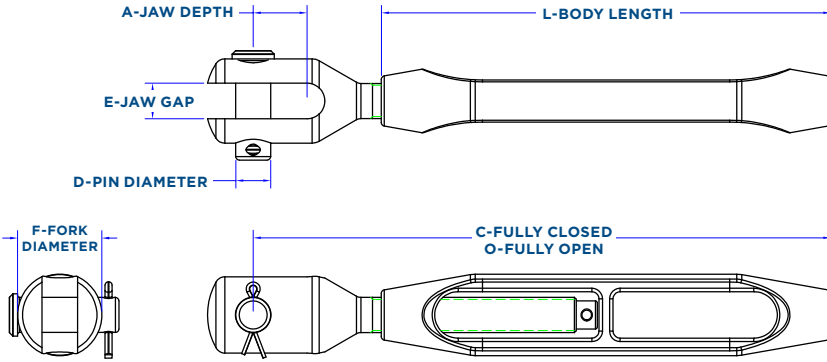

SMART PART # KEY fork pin size | **Forged Bronze Fork**

Part #	Wire Ø	Thread	D-Pin Ø	O-Open L	C-Closed L	L-Body	A-Jaw Depth	E-Jaw Gap	F-Fork Ø	Weight lbs.
14FBF	3/32" - 5/32"	1/4-28	1/4"	6 15/16"	5 7/16"	4 1/2"	3/8"	1/4"	9/16"	0.16
516FBF	5/32" - 3/16"	5/16-24	5/16"	8"	6 3/8"	5"	7/16"	5/16"	23/32"	0.31
38FBF	3/16" - 1/4"	3/8-24	3/8"	8 15/16"	7 3/16"	5 1/2"	9/16"	3/8"	7/8"	0.47
12FBF	1/4" - 5/16"	1/2-20	1/2"	10 7/16"	8 7/16"	6 1/2"	11/16"	1/2"	1 1/8"	1.08
58FBF	5/16" - 3/8"	5/8-18	5/8"	1'-1 3/4"	11 1/4"	8"	15/16"	5/8"	1 1/2"	1.90
34FBF	3/8" - 1/2"	3/4-16	3/4"	1'-3 11/16"	1'-0 11/16"	10"	1"	3/4"	1 7/8"	3.85
78FBF	1/2" - 9/16"	7/8-14	7/8"	1'-7 7/16"	1'-3 11/16"	1'-0 7/16"	1 5/16"	7/8"	2 1/8"	6.23
1FBF	9/16" - 5/8"	1-12	1"	1'-10 3/8"	1'-5 7/8"	1'-2 3/16"	1 15/32"	1"	2 1/2"	8.88
118FBF	3/4"	1 1/8-12	1 1/8"	2'-0 15/16"	1'-8 3/16"	1'-4"	1 3/4"	1 1/8"	2 3/4"	13.95
114FBF	7/8"	1 1/4-12	1 1/4"	2'-3 5/8"	1'-10 3/8"	1'-5 7/8"	1 15/16"	1 1/4"	3"	18.37
138FBF	1"	1 3/8-12	1 3/8"	2'-6 1/4"	2'-0 1/4"	1'-7 1/2"	2 1/8"	1 3/8"	3 1/4"	23.26

STEMBALL AND OPEN BODY

316 Stainless Steel / Chromed Bronze Turnbuckle Body

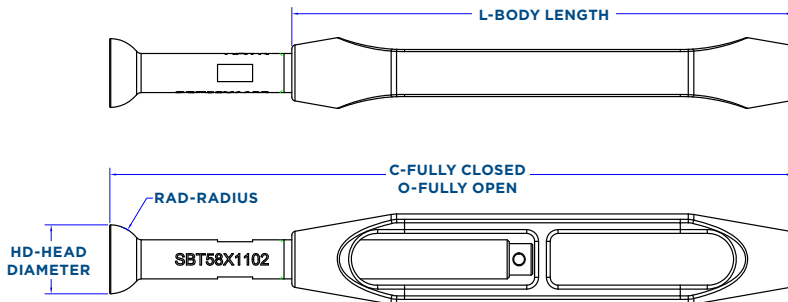

SMART PART # KEY thread size | **Forged Bronze StemBall** | head diameter

Part #	Wire Ø	Thread	HD-Head Diameter	RAD-Radius	O-Open L	C-Closed L	L-Body	Weight lbs.
38FBSB693	3/16" - 1/4"	3/8-24	0.693"	0.346"	8 3/4"	7"	5 1/2"	0.38
12FBSB1000	1/4" - 5/16"	1/2-20	1"	0.472"	10 7/8"	8 7/8"	6 1/2"	0.94
58FBSB1102	5/16" - 3/8"	5/8-18	1.102"	0.551"	1'-1 3/8"	10 7/8"	8"	1.46
34FBSB1102	7/16" - 1/2"	3/4-16	1.102"	0.551"	1'-4 3/8"	1'-1 3/8"	10"	2.90

EYE TOGGLE JAW TO EYE TOGGLE JAW - OPEN BODY

316 Stainless Steel / Chromed Bronze Turnbuckle Body

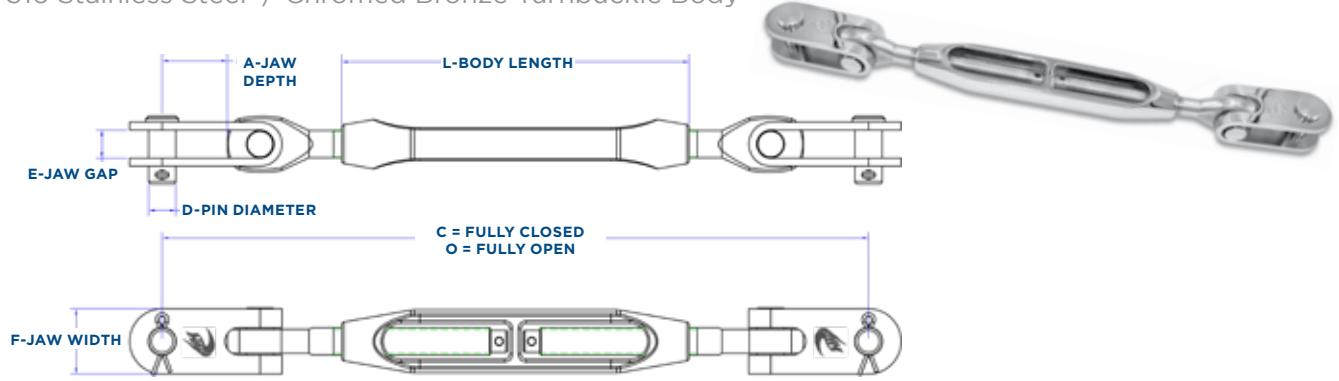

SMART PART # KEY toggle pin size | [Eye Toggle Forged Bronze Jaw](#)

Part #	Wire Ø	Thread	D-Pin Ø	O-Open L	C-Closed L	L-Body	A-Jaw Depth	E-Jaw Gap	F-Jaw Width	Weight lbs.
14ETFBJ	3/32" - 5/32"	1/4-28	1/4"	10 5/8"	7 5/8"	4 1/2"	9/16"	1/4"	5/8"	0.32
516ETFBJ	5/32" - 3/16"	5/16-24	5/16"	11 13/16"	8 9/16"	5"	5/8"	5/16"	3/4"	0.52
38ETFBJ	3/16" - 1/4"	3/8-24	3/8"	1'-1 1/2"	10"	5 1/2"	3/4"	3/8"	7/8"	0.82
716ETFBJ	7/32" - 9/32"	7/16-20	7/16"	1'-3"	11 1/2"	5 7/8"	1 1/4"	7/16"	1 1/16"	1.25
12ETFBJ	1/4" - 5/16"	1/2-20	1/2"	1'-5"	1'-1"	6 1/2"	1 1/8"	1/2"	1 5/32"	1.88
58ETFBJ	5/16" - 3/8"	5/8-18	5/8"	1'-9 1/4"	1'-4 1/4"	8"	1 1/2"	5/8"	1 1/2"	3.61
34ETFBJ	7/16" - 1/2"	3/4-16	3/4"	2'-1 9/16"	1'-7 9/16"	10"	1 7/8"	3/4"	1 7/8"	6.65
78ETFBJ	1/2" - 9/16"	7/8-14	7/8"	2'-7 3/4"	2'-0 1/4"	1'-0 7/16"	2 7/8"	7/8"	2 3/8"	11.45
1ETFBJ	9/16" - 5/8"	1-12	1"	2'-11"	2'-2"	1'-2 3/16"	2 5/8"	1"	2 1/2"	15.70
118ETFBJ	3/4"	1 1/8-12	1 1/8"	3'-2 5/8"	2'-5 1/8"	1'-4"	2 3/4"	1 1/8"	2 3/4"	23.49
114ETFBJ	7/8"	1 1/4-12	1 1/4"	3'-8 15/16"	2'-10 7/16"	1'-5 7/8"	3 7/8"	1 1/4"	3 1/4"	34.37
138ETFBJ	1"	1 3/8-12	1 3/8"	4'-0 5/8"	3'-0 5/8"	1'-7 1/2"	4 5/16"	1 3/8"	4"	47.13

TOGGLE JAW TO TOGGLE JAW - OPEN BODY

316 Stainless Steel / Chromed Bronze Turnbuckle Body

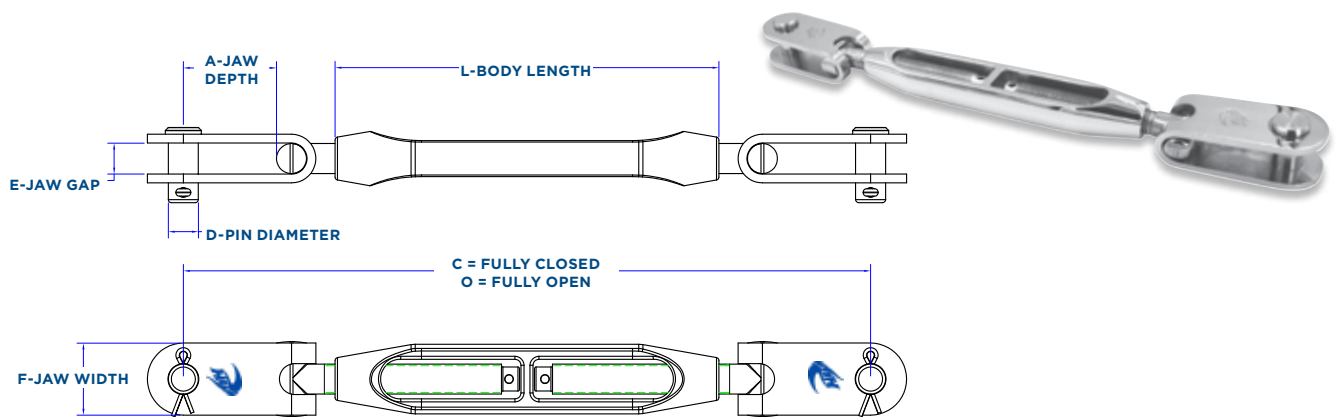

SMART PART # KEY toggle pin size | [Toggle Forged Bronze Jaw](#)

Part #	Wire Ø	Thread	D-Pin Ø	O-Open L	C-Closed L	L-Body	A-Jaw Depth	E-Jaw Gap	F-Jaw Width	Weight lbs.
14TFBJ	3/32" - 5/32"	1/4-28	1/4"	10 3/4"	7 3/4"	4 1/2"	3/4"	1/4"	5/8"	0.30
516TFBJ	5/32" - 3/16"	5/16-24	5/16"	11 7/16"	8 3/16"	5"	13/16"	5/16"	3/4"	0.47
38TFBJ	3/16" - 1/4"	3/8-24	3/8"	1'-0 11/16"	9 3/16"	5 1/2"	1"	3/8"	7/8"	0.72
12TFBJ	1/4" - 5/16"	1/2-20	1/2"	1'-3 7/16"	11 7/16"	6 1/2"	1 7/16"	1/2"	1 5/32"	1.62
58TFBJ	5/16" - 3/8"	5/8-18	5/8"	1'-7 5/16"	1'-2 5/16"	8"	1 15/16"	5/8"	1 1/2"	3.11
34TFBJ	7/16" - 1/2"	3/4-16	3/4"	2'-0 13/16"	1'-6 13/16"	10"	2 5/16"	3/4"	1 7/8"	6.01

EYE TO SWAGE - OPEN BODY

316 Stainless Steel / Chromed Bronze Turnbuckle Body

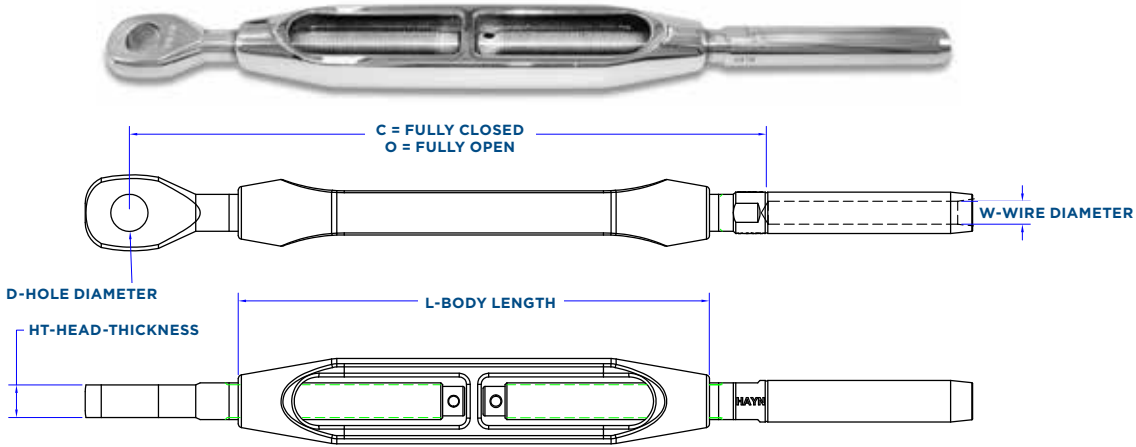

SMART PART # KEY eye pin size | Turnbuckle Forged Bronze Swage | wire size | Eye Imperial Wire Sizes

Part #	W-Wire Ø	Thread	D-Hole Ø	O-Open L	C-Closed L	L-Body	HT-Head Thickness	Weight lbs.
14TFBS332E	3/32"	1/4-28	1/4"	8 13/16"	5 13/16"	4 1/2"	7/32"	0.19
14TFBS18E	1/8"	1/4-28	1/4"	8 13/16"	5 13/16"	4 1/2"	7/32"	0.19
14TFBS532E	5/32"	1/4-28	1/4"	8 7/8"	5 7/8"	4 1/2"	7/32"	0.20
516TFBS532E	5/32"	5/16-24	5/16"	9 3/4"	6 1/2"	5"	1/4"	0.33
516TFBS316E	3/16"	5/16-24	5/16"	9 13/16"	6 9/16"	5"	1/4"	0.35
38TFBS316E	3/16"	3/8-24	3/8"	10 15/16"	7 7/16"	5 1/2"	5/16"	0.52
38TFBS732E	7/32"	3/8-24	3/8"	10 15/16"	7 7/16"	5 1/2"	5/16"	0.54
38TFBS14E	1/4"	3/8-24	3/8"	11"	7 1/2"	5 1/2"	5/16"	0.59
12TFBS14E	1/4"	1/2-20	1/2"	1'-0 7/8"	8 7/8"	6 1/2"	15/32"	1.18
12TFBS932E	9/32"	1/2-20	1/2"	1'-0 15/16"	8 15/16"	6 1/2"	15/32"	1.24
12TFBS16E	5/16"	1/2-20	1/2"	1'-0 15/16"	8 15/16"	6 1/2"	15/32"	1.30
58TFBS16E	5/16"	5/8-18	5/8"	1'-3 13/16"	10 13/16"	8"	9/16"	2.01
58TFBS38E	3/8"	5/8-18	5/8"	1'-3 13/16"	10 13/16"	8"	9/16"	2.09
34TFBS716E	7/16"	3/4-16	3/4"	1'-7 5/16"	1'-1 5/16"	10"	23/32"	4.02
34TFBS12E	1/2"	3/4-16	3/4"	1'-7 5/16"	1'-1 5/16"	10"	23/32"	4.10
78TFBS12E	1/2"	7/8-14	7/8"	1'-11 1/2"	1'-4"	1'-0 7/16"	7/8"	5.98
78TFBS916E	9/16"	7/8-14	7/8"	1'-11 9/16"	1'-4 1/16"	1'-0 7/16"	7/8"	6.95
1TFBS58E	5/8"	1-12	1"	2'-2 5/16"	1'-5 5/16"	1'-2 3/16"	15/16"	10.10
118TFBS34E	3/4"	1 1/8-12	1 1/8"	2'-5 1/4"	1'-7 3/4"	1'-4"	1 1/32"	14.79
114TFBS78E	7/8"	1 1/4-12	1 1/4"	2'-8 7/8"	1'-10 3/8"	1'-5 7/8"	1 3/16"	19.19
138TFBS1E	1"	1 3/8-12	1 3/8"	2'-11 3/8"	1'-11 3/8"	1'-7 1/2"	1 5/16"	28.24

Metric Wire Sizes

Part #	W-Wire Ø	Thread	D-Hole Ø	O-Open L	C-Closed L	L-Body	HT-Head Thickness	Weight lbs.
14TFBSM03E	3mm	1/4-28	1/4"	8 3/4"	5 3/4"	4 1/2"	7/32"	0.19
14TFBSM04E	4mm	1/4-28	1/4"	8 7/8"	5 7/8"	4 1/2"	7/32"	0.20
516TFBSM04E	4mm	5/16-24	5/16"	9 3/4"	6 1/2"	5"	1/4"	0.33
516TFBSM05E	5mm	5/16-24	5/16"	9 13/16"	6 9/16"	5"	1/4"	0.35
38TFBSM05E	5mm	3/8-24	3/8"	10 15/16"	7 7/16"	5 1/2"	5/16"	0.51
38TFBSM06E	6mm	3/8-24	3/8"	11"	7 1/2"	5 1/2"	5/16"	0.59
12TFBSM06E	6mm	1/2-20	1/2"	1'-0 7/8"	8 7/8"	6 1/2"	15/32"	1.19
12TFBSM07E	7mm	1/2-20	1/2"	1'-0 15/16"	8 15/16"	6 1/2"	15/32"	1.24
12TFBSM08E	8mm	1/2-20	1/2"	1'-0 15/16"	8 15/16"	6 1/2"	15/32"	1.30
58TFBSM08E	8mm	5/8-18	5/8"	1'-3 13/16"	10 13/16"	8"	9/16"	2.01
58TFBSM10E	10mm	5/8-18	5/8"	1'-3 13/16"	10 13/16"	8"	9/16"	2.24
34TFBSM12E	12mm	3/4-16	3/4"	1'-7 5/16"	1'-1 5/16"	10"	23/32"	4.15
78TFBSM14E	14mm	7/8-14	7/8"	1'-11 5/8"	1'-4 1/8"	1'-0 7/16"	7/8"	6.95
1TFBSM16E	16mm	1-12	1"	2'-2 5/16"	1'-5 5/16"	1'-2 3/16"	15/16"	10.10
118TFBSM19E	19mm	1 1/8-12	1 1/8"	2'-5 1/4"	1'-7 3/4"	1'-4"	1 1/32"	14.79
114TFBSM22E	22mm	1 1/4-12	1 1/4"	2'-8 7/8"	1'-10 3/8"	1'-5 7/8"	1 3/16"	19.19
138TFBSM26E	26mm	1 3/8-12	1 3/8"	2'-11 3/8"	1'-11 3/8"	1'-7 1/2"	1 5/16"	28.24

EYE TOGGLE JAW AND OPEN BODY

316 Stainless Steel / Chromed Bronze Turnbuckle Body

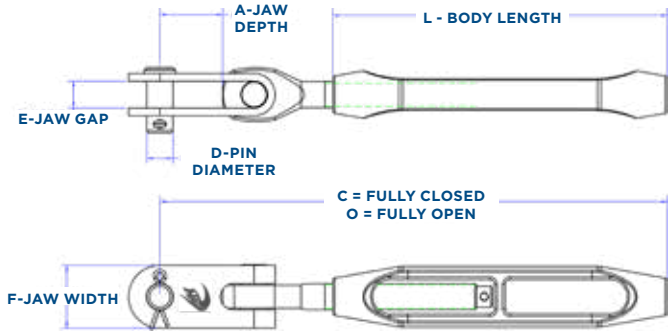

SMART PART # KEY toggle pin size | [Eye Forged Bronze Jaw](#)

Part #	Wire Ø	Thread	D-Pin Ø	O-Open L	C-Closed L	L-Body	A-Jaw Depth	E-Jaw Gap	F-Jaw Width	Weight lbs.
14EFBJ	3/32" - 5/32"	1/4-28	1/4"	7 9/16"	6 1/16"	4 1/2"	9/16"	1/4"	5/8"	0.21
516EFBJ	5/32" - 3/16"	5/16-24	5/16"	8 7/16"	6 13/16"	5"	5/8"	5/16"	3/4"	0.35
38EFBJ	3/16" - 1/4"	3/8-24	3/8"	9 1/2"	7 3/4"	5 1/2"	3/4"	3/8"	7/8"	0.53
716EFBJ	7/32" - 9/32"	7/16-20	7/16"	10 7/16"	8 11/16"	5 7/8"	1 1/4"	7/16"	1 1/16"	0.89
12EFBJ	1/4" - 5/16"	1/2-20	1/2"	11 3/4"	9 3/4"	6 1/2"	1 1/8"	1/2"	1 5/32"	1.26
58EFBJ	5/16" - 3/8"	5/8-18	5/8"	1'-2 5/8"	1'-0 1/8"	8"	1 1/2"	5/8"	1 1/2"	2.33
34EFBJ	7/16" - 1/2"	3/4-16	3/4"	1'-5 13/16"	1'-2 13/16"	10"	1 7/8"	3/4"	1 7/8"	4.22
78EFBJ	1/2" - 9/16"	7/8-14	7/8"	1'-10 1/16"	1'-6 5/16"	1'-0 7/16"	2 7/8"	7/8"	2 3/8"	7.45
1EFBJ	9/16" - 5/8"	1-12	1"	2'-0 9/16"	1'-8 1/16"	1'-2 3/16"	2 5/8"	1"	2 1/2"	10.40
118EFBJ	3/4"	1 1/8-12	1 1/8"	2'-3 5/16"	1'-10 9/16"	1'-4"	2 3/4"	1 1/8"	2 3/4"	15.47
114EFBJ	7/8"	1 1/4-12	1 1/4"	2'-7 3/8"	2'-2 1/8"	1'-5 7/8"	3 7/8"	1 1/4"	3 1/4"	22.20
138EFBJ	1"	1 3/8-12	1 3/8"	2'-10 1/16"	2'-4 1/16"	1'-7 1/2"	4 5/16"	1 3/8"	4"	29.51

Increased jaw depths available. Call for details.

TOGGLE JAW AND OPEN BODY

316 Stainless Steel / Chromed Bronze Turnbuckle Body

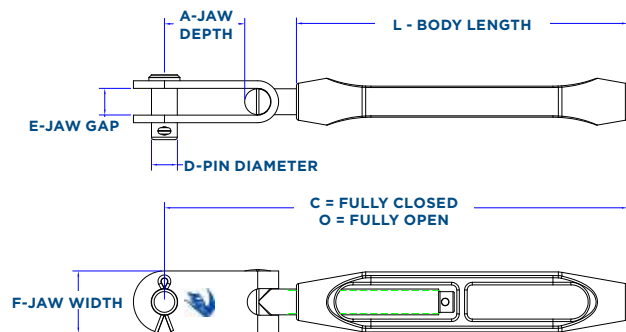

SMART PART # KEY toggle pin size | [Forged Bronze Jaw](#)

Part #	Wire Ø	Thread	D-Pin Ø	O-Open L	C-Closed L	L-Body	A-Jaw Depth	E-Jaw Gap	F-Jaw Width	Weight lbs.
14FBJ	3/32" - 5/32"	1/4-28	1/4"	7 5/8"	6 1/8"	4 1/2"	3/4"	1/4"	5/8"	0.20
516FBJ	5/32" - 3/16"	5/16-24	5/16"	8 1/4"	6 5/8"	5"	13/16"	5/16"	3/4"	0.33
38FBJ	3/16" - 1/4"	3/8-24	3/8"	9 1/8"	7 3/8"	5 1/2"	1"	3/8"	7/8"	0.49
12FBJ	1/4" - 5/16"	1/2-20	1/2"	10 15/16"	8 15/16"	6 1/2"	1 7/16"	1/2"	1 5/32"	1.13
58FBJ	5/16" - 3/8"	5/8-18	5/8"	1'-1 3/4"	11 1/4"	8"	1 15/16"	5/8"	1 1/2"	2.06
34FBJ	7/16" - 1/2"	3/4-16	3/4"	1'-5 7/16"	1'-2 7/16"	10"	2 5/16"	3/4"	1 7/8"	3.81

EYE TOGGLE JAW AND CLOSED BODY

316 Stainless Steel

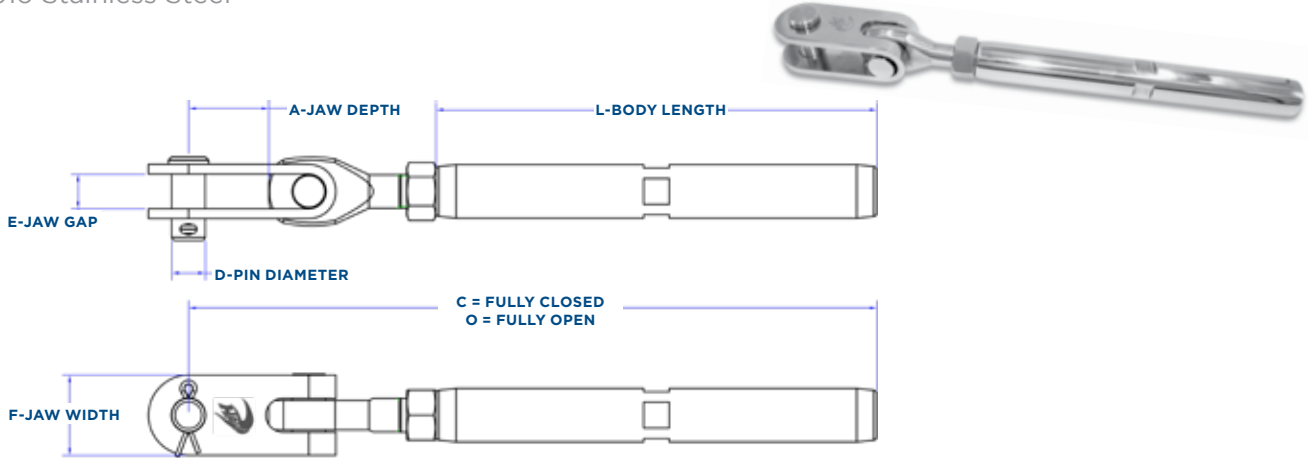

SMART PART # KEY eye toggle pin size | [Eye Tubular Turnbuckle Jaw Toggle](#)

Part #	Wire Ø	Thread	D-Pin Ø	O-Open L	C-Closed L	L-Body	A-Jaw Depth	E-Jaw Gap	F-Jaw Width	Weight lbs.
14ETTJT	3/32" - 5/32"	1/4-28	1/4"	7 7/16"	5 15/16"	4 1/4"	9/16"	1/4"	21/32"	0.19
516ETTJT	5/32" - 3/16"	5/16-24	5/16"	8 5/8"	7"	5"	5/8"	5/16"	3/4"	0.34
38ETTJT	3/16" - 1/4"	3/8-24	3/8"	9 7/8"	8"	5 1/2"	3/4"	3/8"	57/64"	0.48
12ETTJT	1/4" - 5/16"	1/2-20	1/2"	1'-0"	10"	6 1/2"	1 1/8"	1/2"	1 5/32"	1.04
58ETTJT	5/16" - 3/8"	5/8-18	5/8"	1'-3 3/8"	1'-0 7/8"	8 1/4"	1 1/2"	5/8"	1 1/2"	2.35
34ETTJT	7/16" - 1/2"	3/4-16	3/4"	1'-6 1/16"	1' 3 1/16"	9 3/4"	1 7/8"	3/4"	1 7/8"	3.86
78ETTJT	1/2" - 9/16"	7/8-14	7/8"	1'-9 1/8"	1'-5 5/8"	11"	2 7/8"	7/8"	2 3/8"	6.80
1ETTJT	9/16" - 5/8"	1-12	1"	1'-11 3/4"	1'-8"	1'-1"	2 5/8"	1"	2 1/2"	9.52

TOGGLE JAW AND CLOSED BODY

316 Stainless Steel

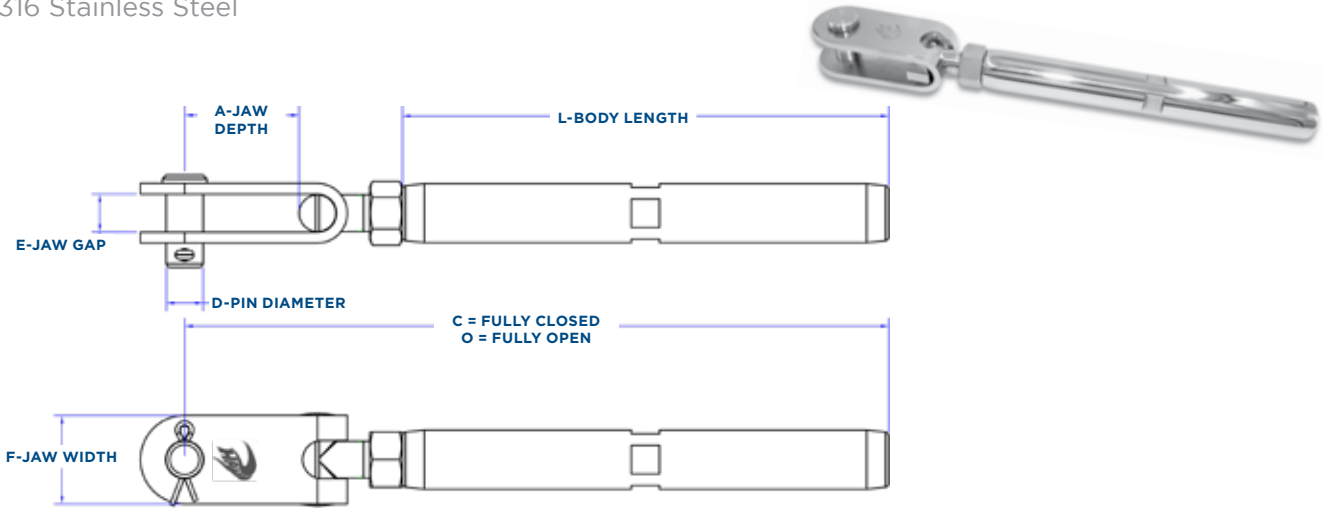

SMART PART # KEY toggle pin size | [Tubular Turnbuckle Jaw Toggle](#)

Part #	Wire Ø	Thread	D-Pin Ø	O-Open L	C-Closed L	L-Body	A-Jaw Depth	E-Jaw Gap	F-Jaw Width	Weight lbs.
14TTJT	3/32" - 5/32"	1/4-28	1/4"	7 1/2"	6"	4 1/4"	3/4"	1/4"	21/32"	0.18
516TTJT	5/32" - 3/16"	5/16-24	5/16"	8 7/16"	6 13/16"	5"	13/16"	5/16"	3/4"	0.30
38TTJT	3/16" - 1/4"	3/8-24	3/8"	9 1/2"	7 5/8"	5 1/2"	1"	3/8"	57/64"	0.43
12TTJT	1/4" - 5/16"	1/2-20	1/2"	11 5/16"	9 5/16"	6 1/2"	1 7/16"	1/2"	1 5/32"	0.93
58TTJT	5/16" - 3/8"	5/8-18	5/8"	1'-2 7/16"	11 15/16"	8 1/4"	1 15/16"	5/8"	1 1/2"	2.12
34TTJT	7/16" - 1/2"	3/4-16	3/4"	1'-5 11/16"	1'-2 11/16"	9 3/4"	2 5/16"	3/4"	1 7/8"	3.60

EYE TOGGLE JAW TO SWAGE - CLOSED BODY

316 Stainless Steel

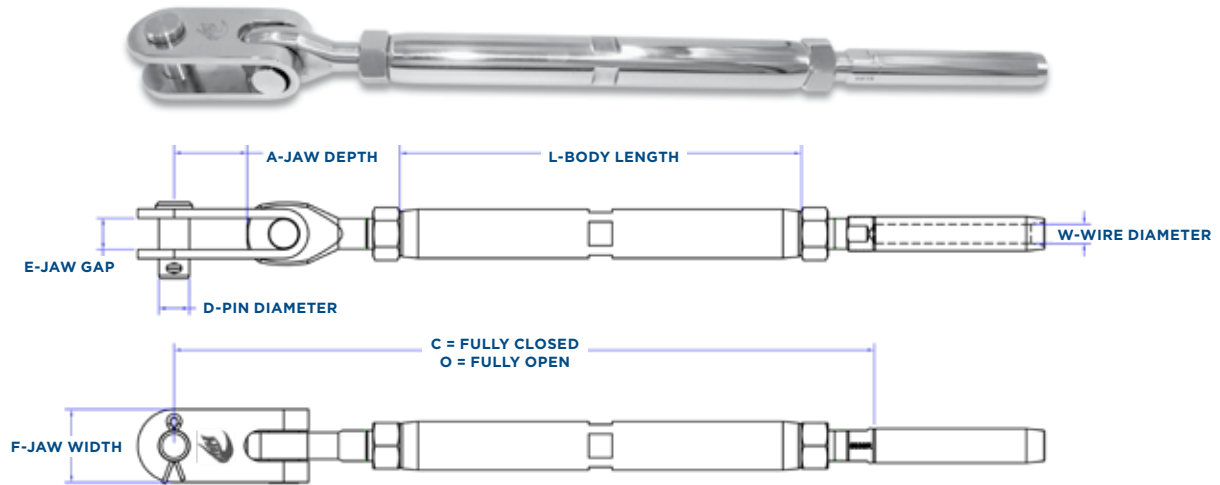

SMART PART # KEY eye toggle pin size | Eye Tubular Turnbuckle Swage | wire size

Imperial Wire Sizes

Part #	W-Wire Ø	Thread	D-Pin Ø	O-Open L	C-Closed L	L-Body	A-Jaw Depth	E-Jaw Gap	F-Jaw Width	Weight lbs.
14ETTS332	3/32"	1/4-28	1/4"	9 3/4"	6 3/4"	4 1/4"	9/16"	1/4"	21/32"	0.23
14ETTS18	1/8"	1/4-28	1/4"	9 11/16"	6 11/16"	4 1/4"	9/16"	1/4"	21/32"	0.24
14ETTS532	5/32"	1/4-28	1/4"	9 11/16"	6 11/16"	4 1/4"	9/16"	1/4"	21/32"	0.25
516ETTS532	5/32"	5/16-24	5/16"	11 1/8"	7 7/8"	5"	5/8"	5/16"	3/4"	0.41
516ETTS316	3/16"	5/16-24	5/16"	11 3/16"	7 15/16"	5"	5/8"	5/16"	3/4"	0.43
38ETTS316	3/16"	5/16-24	5/16"	1'-0 15/16"	9 3/16"	5 1/2"	3/4"	3/8"	57/64"	0.62
38ETTS732	7/32"	3/8-24	3/8"	1'-0 15/16"	9 3/16"	5 1/2"	3/4"	3/8"	57/64"	0.65
38ETTS14	1/4"	3/8-24	3/8"	1'-1"	9 1/4"	5 1/2"	3/4"	3/8"	57/64"	0.70
12ETTS14	1/4"	1/2-20	1/2"	1'-3 5/16"	11 5/16"	6 1/2"	1 1/8"	1/2"	1 5/32"	1.36
12ETTS932	9/32"	1/2-20	1/2"	1'-3 5/16"	11 5/16"	6 1/2"	1 1/8"	1/2"	1 5/32"	1.41
12ETTS516	5/16"	1/2-20	1/2"	1'-3 5/16"	11 5/16"	6 1/2"	1 1/8"	1/2"	1 5/32"	1.47
58ETTS516	5/16"	5/8-18	5/8"	1'-7 1/4"	1'-2 1/4"	8 1/4"	1 1/2"	5/8"	1 1/2"	2.99
58ETTS38	3/8"	5/8-18	5/8"	1'-7 1/4"	1'-2 1/4"	8 1/4"	1 1/2"	5/8"	1 1/2"	3.08
34ETTS716	7/16"	3/4-16	3/4"	1'-10 13/16"	1'-4 13/16"	9 3/4"	1 7/8"	3/4"	1 7/8"	5.00
34ETTS12	1/2"	3/4-16	3/4"	1'-10 13/16"	1'-4 13/16"	9 3/4"	1 7/8"	3/4"	1 7/8"	5.14
78ETTS12	1/2"	7/8-14	7/8"	2'-3"	1'-8"	11"	2 7/8"	7/8"	2 3/8"	8.80
78ETTS916	9/16"	7/8-14	7/8"	2'-3 1/8"	1'-8 1/8"	11"	2 7/8"	7/8"	2 3/8"	9.15
1ETTS916	9/16"	1-12	1"	2'-5 7/8"	1'-10 3/8"	1'-1"	2 5/8"	1"	2 1/2"	11.82
1ETTS58	5/8"	1-12	1"	2'-5 11/16"	1'-10 3/16"	1'-1"	2 5/8"	1"	2 1/2"	12.26

Metric Wire Sizes

Part #	W-Wire Ø	Thread	D-Pin Ø	O-Open L	C-Closed L	L-Body	A-Jaw Depth	E-Jaw Gap	F-Jaw Width	Weight lbs.
14ETTSM03	3mm	1/4-28	1/4"	9 11/16"	6 11/16"	4 1/4"	9/16"	1/4"	21/32"	0.24
14ETTSM04	4mm	1/4-28	1/4"	9 11/16"	6 11/16"	4 1/4"	9/16"	1/4"	21/32"	0.25
516ETTSM04	4mm	5/16-24	5/16"	11 1/8"	7 7/8"	5"	5/8"	5/16"	3/4"	0.41
516ETTSM05	5mm	5/16-24	5/16"	11 3/16"	7 15/16"	5"	5/8"	5/16"	3/4"	0.43
38ETTSM05	5mm	3/8-24	3/8"	1'-1 1/8"	9 3/8"	5 1/2"	3/4"	3/8"	57/64"	0.62
38ETTSM06	6mm	3/8-24	3/8"	1'-1"	9 1/4"	5 1/2"	3/4"	3/8"	57/64"	0.70
12ETTSM06	6mm	1/2-20	1/2"	1'-3 5/16"	11 5/16"	6 1/2"	1 1/8"	1/2"	1 5/32"	1.36
12ETTSM07	7mm	1/2-20	1/2"	1'-3 5/16"	11 5/16"	6 1/2"	1 1/8"	1/2"	1 5/32"	1.41
12ETTSM08	8mm	1/2-20	1/2"	1'-3 5/16"	11 5/16"	6 1/2"	1 1/8"	1/2"	1 5/32"	1.48
58ETTSM08	8mm	5/8-18	5/8"	1'-7 1/4"	1'-2 1/4"	8 1/4"	1 1/2"	5/8"	1 1/2"	2.99
58ETTSM10	10mm	5/8-18	5/8"	1'-7 1/4"	1'-2 1/4"	8 1/4"	1 1/2"	5/8"	1 1/2"	3.06
34ETTSM11	11mm	3/4-16	3/4"	1'-10 13/16"	1'-4 13/16"	9 3/4"	1 7/8"	3/4"	1 7/8"	5.03
34ETTSM12	12mm	3/4-16	3/4"	1'-10 13/16"	1'-4 13/16"	9 3/4"	1 7/8"	3/4"	1 7/8"	5.18
78ETTSM12	12mm	7/8-14	7/8"	2'-3"	1'-8"	11"	2 7/8"	7/8"	2 3/8"	8.60
78ETTSM14	14mm	7/8-14	7/8"	2'-3 1/8"	1'-8 1/8"	11"	2 7/8"	7/8"	2 3/8"	11.82
1ETTSM16	16mm	1-12	1"	2'-5 11/16"	1'-10 3/16"	1'-1"	2 5/8"	1"	2 1/2"	12.26

TOGGLE JAW TO SWAGE - CLOSED BODY

316 Stainless Steel

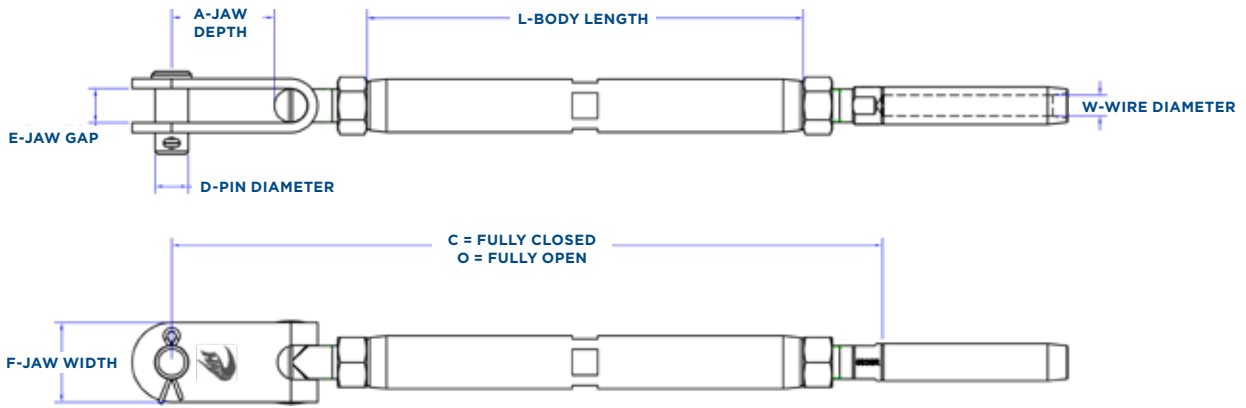

SMART PART # KEY toggle pin size | Tubular Turnbuckle Swage | wire size

Imperial Wire Sizes

Part #	W-Wire Ø	Thread	D-Pin Ø	O-Open L	C-Closed L	L-Body	A-Jaw Depth	E-Jaw Gap	F-Jaw Width	Weight lbs.
14TTS332	3/32"	1/4-28	1/4"	9 3/4"	6 3/4"	4 1/4"	3/4"	1/4"	21/32"	0.22
14TTS18	1/8"	1/4-28	1/4"	9 3/4"	6 3/4"	4 1/4"	3/4"	1/4"	21/32"	0.23
14TTS532	5/32"	1/4-28	1/4"	9 3/4"	6 3/4"	4 1/4"	3/4"	1/4"	21/32"	0.24
516TTS532	5/32"	5/16-24	5/16"	10 15/16"	7 11/16"	5"	13/16"	5/16"	3/4"	0.38
516TTS316	3/16"	5/16-24	5/16"	11"	7 3/4"	5"	13/16"	5/16"	3/4"	0.411
38TTS316	3/16"	3/8-24	3/8"	1'-0 1/2"	8 3/4"	5 1/2"	1"	3/8"	57/64"	0.58
38TTS732	7/32"	3/8-24	3/8"	1'-0 1/2"	8 3/4"	5 1/2"	1"	3/8"	57/64"	0.60
38TTS14	1/4"	3/8-24	3/8"	1'-0 5/8"	8 7/8"	5 1/2"	1"	3/8"	57/64"	0.65
12TTS14	1/4"	1/2-20	1/2"	1'-2 9/16"	10 9/16"	6 1/2"	1 7/16"	1/2"	1 5/32"	1.25
12TTS932	9/32"	1/2-20	1/2"	1'-2 9/16"	10 9/16"	6 1/2"	1 7/16"	1/2"	1 5/32"	1.30
12TTS516	5/16"	1/2-20	1/2"	1'-2 9/16"	10 9/16"	6 1/2"	1 7/16"	1/2"	1 5/32"	1.32
58TTS516	5/16"	5/8-18	5/8"	1'-6 5/16"	1'-1 5/16"	8 1/4"	1 15/16"	5/8"	1 1/2"	2.77
58TTS38	3/8"	5/8-18	5/8"	1'-6 5/16"	1'-1 5/16"	8 1/4"	1 15/16"	5/8"	1 1/2"	2.86
34TTS716	7/16"	3/4-16	3/4"	1'-10 7/16"	1'-4 7/16"	9 3/4"	2 5/16"	3/4"	1 7/8"	4.84
34TTS12	1/2"	3/4-16	3/4"	1'-10 7/16"	1'-4 7/16"	9 3/4"	2 5/16"	3/4"	1 7/8"	4.91

Metric Wire Sizes

Part #	W-Wire Ø	Thread	D-Pin Ø	O-Open L	C-Closed L	L-Body	A-Jaw Depth	E-Jaw Gap	F-Jaw Width	Weight lbs.
14TTSM03	3mm	1/4-28	1/4"	9 3/4"	6 3/4"	4 1/4"	3/4"	1/4"	21/32"	0.23
14TTSM04	4mm	1/4-28	1/4"	9 3/4"	6 3/4"	4 1/4"	3/4"	1/4"	21/32"	0.24
516TTSM04	4mm	5/16-24	5/16"	10 15/16"	7 11/16"	5"	13/16"	5/16"	3/4"	0.39
516TTSM05	5mm	5/16-24	5/16"	11"	7 3/4"	5"	13/16"	5/16"	3/4"	0.41
38TTSM05	5mm	3/8-24	3/8"	1'-0 1/2"	8 3/4"	5 1/2"	1"	3/8"	57/64"	0.58
38TTSM06	6mm	3/8-24	3/8"	1'-0 5/8"	8 7/8"	5 1/2"	1"	3/8"	57/64"	0.65
12TTSM06	6mm	1/2-20	1/2"	1'-2 9/16"	10 9/16"	6 1/2"	1 7/16"	1/2"	1 5/32"	1.25
12TTSM07	7mm	1/2-20	1/2"	1'-2 9/16"	10 9/16"	6 1/2"	1 7/16"	1/2"	1 5/32"	1.30
12TTSM08	8mm	1/2-20	1/2"	1'-2 9/16"	10 9/16"	6 1/2"	1 7/16"	1/2"	1 5/32"	1.37
58TTSM08	8mm	5/8-18	5/8"	1'-6 5/16"	1'-1 5/16"	8 1/4"	1 15/16"	5/8"	1 1/2"	2.77
58TTSM10	10mm	5/8-18	5/8"	1'-6 5/16"	1'-1 5/16"	8 1/4"	1 15/16"	5/8"	1 1/2"	2.84
34TTSM11	11mm	3/4-16	3/4"	1'-10 7/16"	1'-4 7/16"	9 3/4"	2 5/16"	3/4"	1 7/8"	4.81
34TTSM12	12mm	3/4-16	3/4"	1'-10 7/16"	1'-4 7/16"	9 3/4"	2 5/16"	3/4"	1 7/8"	4.95

EYE TOGGLE JAW TO EYE TOGGLE JAW - CLOSED BODY

316 Stainless Steel

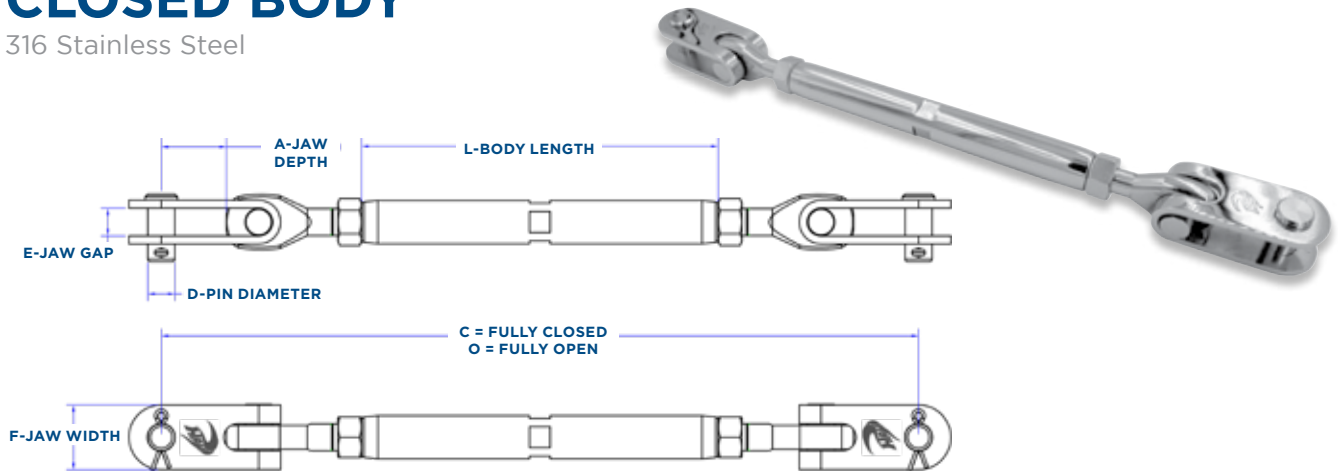

SMART PART # KEY eye toggle pin size | Eye Tubular Turnbuckle Jaw

Part #	Wire Ø	Thread	D-Pin Ø	O-Open L	C-Closed L	L-Body	A-Jaw Depth	E-Jaw Gap	F-Jaw Width	Weight lbs.
14ETTJ	3/32" - 5/32"	1/4-28	1/4"	10 5/8"	7 5/8"	4 1/4"	9/16"	1/4"	21/32"	0.30
516ETTJ	5/32" - 3/16"	5/16-24	5/16"	1'-0 3/16"	8 15/16"	5"	5/8"	5/16"	3/4"	0.50
38ETTJ	3/16" - 1/4"	3/8-24	3/8"	1'-2 1/4"	10 1/2"	5 1/2"	3/4"	3/8"	57/64"	0.81
12ETTJ	1/4" - 5/16"	1/2-20	1/2"	1'-5 5/8"	1'-1 5/8"	6 1/2"	1 1/8"	1/2"	1 5/32"	1.72
58ETTJ	5/16" - 3/8"	5/8-18	5/8"	1'-10 3/8"	1'-5 3/8"	8 1/4"	1 1/2"	5/8"	1 1/2"	3.80
34ETTJ	7/16" - 1/2"	3/4-16	3/4"	2'-2 3/8"	1'-8 3/8"	9 3/4"	1 7/8"	3/4"	1 7/8"	6.20
78ETTJ	1/2" - 9/16"	7/8-14	7/8"	2'-7 5/16"	2'-0 5/16"	11"	2 7/8"	7/8"	2 3/8"	11.05
1ETTJ	9/16" - 5/8"	1-12	1"	2'-10 1/2"	2'-3"	1'-1"	2 5/8"	1"	2 1/2"	14.90

TOGGLE JAW TO TOGGLE JAW - CLOSED BODY

316 Stainless Steel

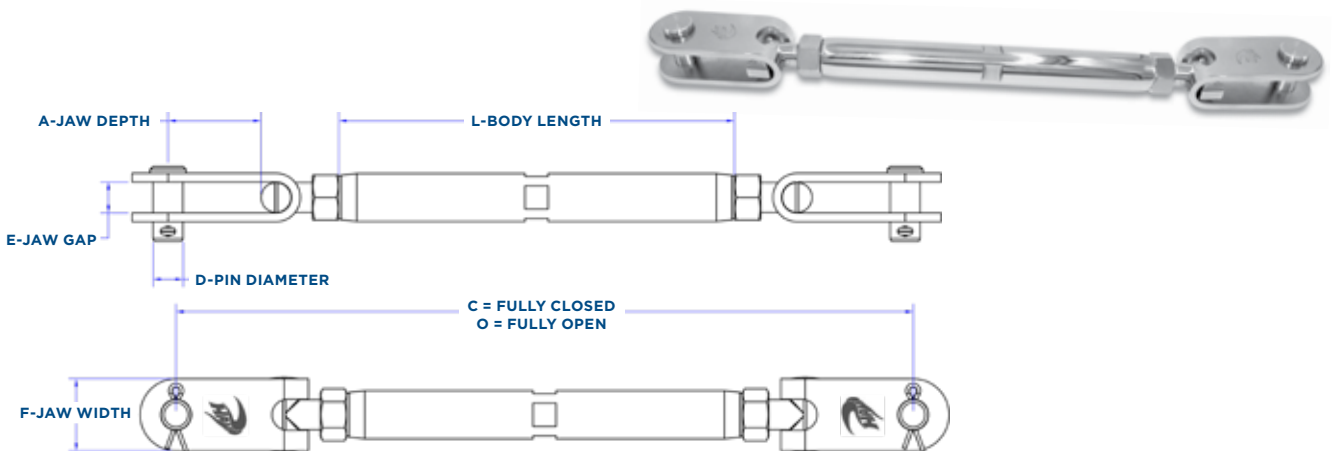

SMART PART # KEY toggle pin size | Tubular Turnbuckle Jaw

Part #	Wire Ø	Thread	D-Pin Ø	O-Open L	C-Closed L	L-Body	A-Jaw Depth	E-Jaw Gap	F-Jaw Width	Weight lbs.
14TTJ	3/32" - 5/32"	1/4-28	1/4"	10 3/4"	7 3/4"	4 1/4"	3/4"	1/4"	21/32"	0.28
516TTJ	5/32" - 3/16"	5/16-24	5/16"	11 13/16"	8 9/16"	5"	13/16"	5/16"	3/4"	0.48
38TTJ	3/16" - 1/4"	3/8-24	3/8"	1'-1 1/2"	9 3/4"	5 1/2"	1"	3/8"	57/64"	0.69
12TTJ	1/4" - 5/16"	1/2-20	1/2"	1'-4 1/8"	1'-0 1/8"	6 1/2"	1 7/16"	1/2"	1 5/32"	1.46
58TTJ	5/16" - 3/8"	5/8-18	5/8"	1'-8 1/2"	1'-3 1/2"	8 1/4"	1 15/16"	5/8"	1 1/2"	3.27
34TTJ	3/8" - 1/2"	3/4-16	3/4"	2'-1 11/16"	1'-7 11/16"	9 3/4"	2 5/16"	3/4"	1 7/8"	5.64

EYE TO SWAGE - CLOSED BODY

316 Stainless Steel

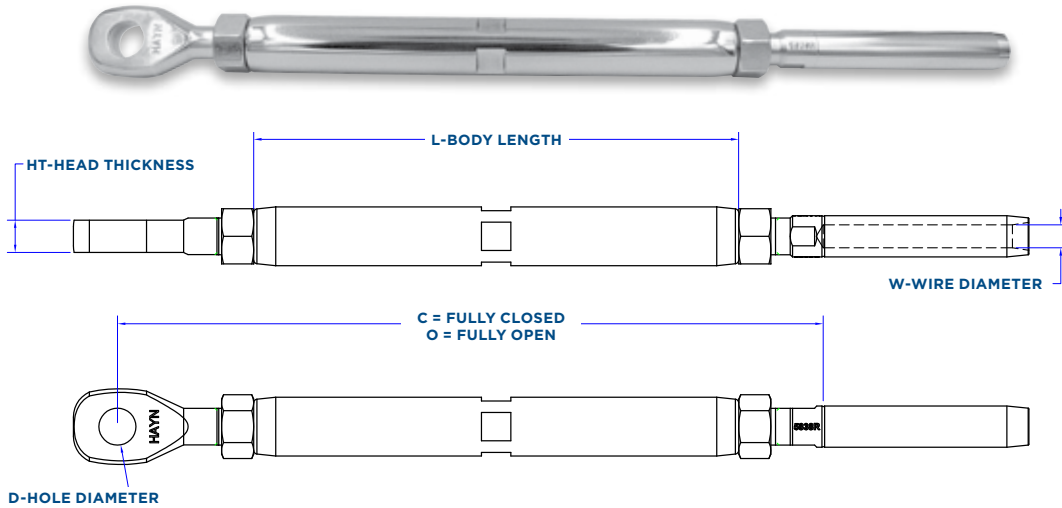

SMART PART # KEY toggle pin size | Tubular Turnbuckle Swage | wire size | Eye

Imperial Wire Sizes

Part #	W-Wire Ø	Thread	D-Hole Ø	O-Open L	C-Closed L	L-Body	HT-Head Thickness	Weight lbs.
14TTS332E	3/32"	1/4-28	1/4"	8 13/16"	5 13/16"	4 1/4"	7/32"	0.16
14TTS18E	1/8"	1/4-28	1/4"	8 13/16"	5 13/16"	4 1/4"	7/32"	0.17
14TTS532E	5/32"	1/4-28	1/4"	8 13/16"	5 13/16"	4 1/4"	7/32"	0.18
516TTS532E	5/32"	5/16-24	5/16"	10 1/8"	6 7/8"	5"	1/4"	0.32
516TTS316E	3/16"	5/16-24	5/16"	10 1/4"	7"	5"	1/4"	0.33
38TTS316E	3/16"	5/16-24	5/16"	11 11/16"	7 15/16"	5 1/2"	5/16"	0.49
38TTS732E	7/32"	3/8-24	3/8"	11 11/16"	7 15/16"	5 1/2"	5/16"	0.52
38TTS14E	1/4"	3/8-24	3/8"	11 3/4"	8"	5 1/2"	5/16"	0.56
12TTS14E	1/4"	1/2-20	1/2"	1'-1 5/8"	9 5/8"	6 1/2"	7/16"	1.00
12TTS932E	9/32"	1/2-20	1/2"	1'-1 5/8"	9 5/8"	6 1/2"	7/16"	1.05
12TTS516E	5/16"	1/2-20	1/2"	1'-1 5/8"	9 5/8"	6 1/2"	7/16"	1.12
58TTS516E	5/16"	5/8-18	5/8"	1'-5"	1'-0"	8 1/4"	9/16"	2.31
58TTS38E	3/8"	5/8-18	5/8"	1'-5"	1'-0"	8 1/4"	9/16"	2.42
34TTS716E	7/16"	3/4-16	3/4"	1'-8 1/8"	1'-2 1/8"	9 3/4"	23/32"	3.58
34TTS12E	1/2"	3/4-16	3/4"	1'-8 1/8"	1'-2 1/8"	9 3/4"	23/32"	3.62
78TTS12E	1/2"	7/8-14	7/8"	1'-11 1/16"	1'-4 1/16"	11"	7/8"	6.16
78TTS916E	9/16"	7/8-14	7/8"	1'-11 1/8"	1'-4 1/8"	11"	7/8"	6.50
1TTS916E	9/16"	1-12	1"	2'-2 1/16"	1'-6 9/16"	1'-1"	15/16"	8.67
1TTS58E	5/8"	1-12	1"	2'-1 7/8"	1'-6 3/8"	1'-1"	15/16"	9.11

Metric Wire Sizes

Part #	W- Wire Ø	Thread	D-Hole Ø	O-Open L	C-Closed L	L-Body	HT-Head Thickness	Weight lbs.
14TTSM03E	3mm	1/4-28	1/4"	8 13/16"	5 13/16"	4 1/4"	7/32"	0.17
14TTSM04E	4mm	1/4-28	1/4"	8 13/16"	5 13/16"	4 1/4"	7/32"	0.18
516TTSM04E	4mm	5/16-24	5/16"	10 1/8"	6 7/8"	5"	1/4"	0.32
516TTSM05E	5mm	5/16-24	5/16"	10 1/4"	7"	5"	1/4"	0.34
38TTSM05E	5mm	3/8-24	3/8"	11 7/8"	8 1/8"	5 1/2"	5/16"	0.47
38TTSM06E	6mm	3/8-24	3/8"	11 3/4"	8"	5 1/2"	5/16"	0.55
12TTSM06E	6mm	1/2-20	1/2"	1'-1 5/8"	9 5/8"	6 1/2"	7/16"	1.01
12TTSM07E	7mm	1/2-20	1/2"	1'-1 5/8"	9 5/8"	6 1/2"	7/16"	1.05
12TTSM08E	8mm	1/2-20	1/2"	1'-1 5/8"	9 5/8"	6 1/2"	7/16"	1.12
58TTSM08E	8mm	5/8-18	5/8"	1'-5"	1'-0"	8 1/4"	9/16"	2.31
58TTSM10E	10mm	5/8-18	5/8"	1'-5"	1'-0"	8 1/4"	9/16"	2.38
34TTSM12E	12mm	3/4-16	3/4"	1'-8 1/8"	1'-2 1/8"	9 3/4"	23/32"	3.74
78TTSM14E	14mm	7/8-14	7/8"	1'-11 3/16"	1'-4 3/16"	11"	7/8"	6.50
1TTSM14E	14mm	1-12	1"	2'-2 1/16"	1'-6 9/16"	1'-1"	15/16"	8.67
1TTSM16E	16mm	1-12	1"	2'-1 7/8"	1'-6 3/8"	1'-1"	15/16"	9.11

NOTE: Can be used with eye toggle stampings for "upset" reverse toggle applications. See page 76.

5/8" and larger turnbuckle assemblies have bronze thread insert for a non-galling feature.

TURNBUCKLE BODY - OPEN

Chromed Bronze

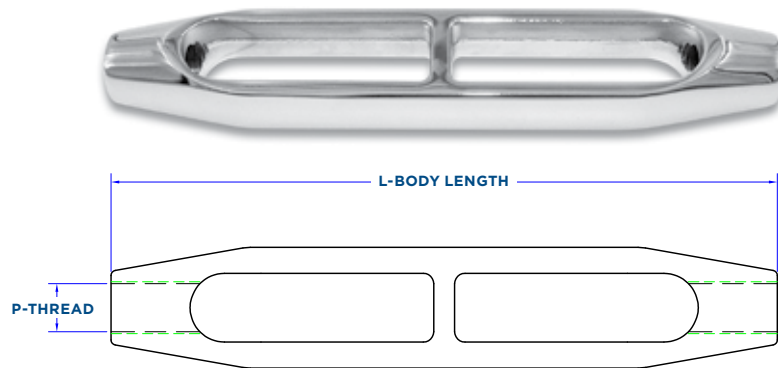

Part #	P-Thread	L-Body Length	Weight lbs.
14FB	1/4-28	4 1/2"	0.10
516FB	5/16-24	5"	0.18
38FB	3/8-24	5 1/2"	0.25
716FB	7/16-20	5 7/8"	0.35
12FB	1/2-20	6 1/2"	0.61
58FB	5/8-18	8"	0.87
34FB	3/4-16	10"	1.93
78FB	7/8-14	1'-0 7/16"	3.44
1FB	1-12	1'-2 3/16"	5.03
118FB	1 1/8-12	1'-4"	7.44
114FB	1 1/4-12	1'-5 7/8"	10.26
138FB	1 3/8-12	1'-7 1/2"	12.69

TURNBUCKLE BODY - CLOSED

316 Stainless Steel

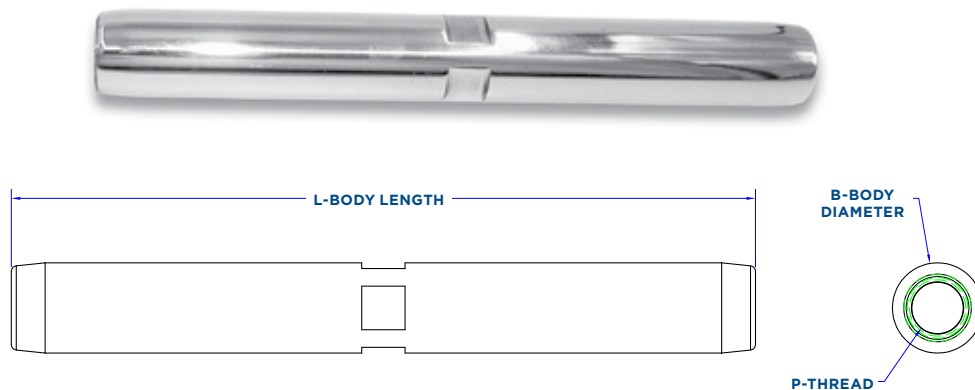

Part #	P-Thread	L-Body Length	B-Body Ø	Weight lbs.
14TB2	1/4-28	2 3/4"	7/16"	0.04
14TB	1/4-28	4 1/4"	7/16"	0.07
516TB	5/16-24	5"	35/64"	0.14
38TB	3/8-24	5 1/2"	5/8"	0.18
12TB	1/2-20	6 1/2"	3/4"	0.35
58TB	5/8-18	8 1/4"	1"	1.03
34TB	3/4-16	9 3/4"	1 1/8"	1.36
78TB	7/8-14	11"	1 3/8"	2.62
1TB	1-12	1'-1"	1 1/2"	3.50

NOTE: 5/8" and larger tubular turnbuckle bodies have bronze thread insert for a non-galling feature.

Hi-MOD COMPRESSION TERMINALS & FAILSAFE INSULATORS

- 35** Introduction
- 36** Compression Fittings Cone Configuration Chart
- 37** Compression Eyes
- 38** Compression Studs
- 39** Compression Toggles
- 40** Compression Forks
- 41** Compression Extenders / Splice Links
- 42** Failsafe Insulators





Produced by Petersen Stainless in the UK and distributed exclusively by Hayn Enterprises in the USA, the Hi-MOD mechanical terminal is the latest approach in swageless fittings. The terminal design includes a unique crown ring that arranges the wire strands for even spacing around the fitting. This allows each strand to experience the load equally. The design also eliminates the need to bend the wires around the cone, which ensures the cone is in the proper location, and keeps the strands from dropping into the cone slots. These advantages,

combined with a longer cone with a more shallow angle, give you the most secure and efficient swageless terminal on the market today. Both the cone and crown ring are fully re-usable allowing for easy inspection and re-use without having to replace anything.

We do not require the use of sealant in our fittings. You can, however, fill them with a non-acidic polysulfide or better marine-grade sealant.

INSTALLATION INSTRUCTIONS

For detailed installation instructions and demo videos visit www.hi-mod.com. Any further questions call toll free at **800-346-4296**.

IMPORTANT:

Do not overtighten. We are not responsible for galled threads caused by overtightening.

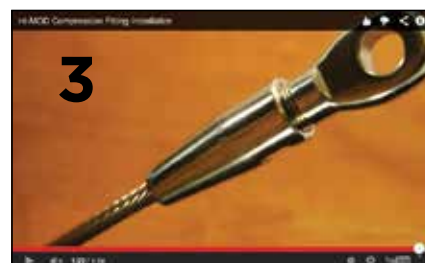
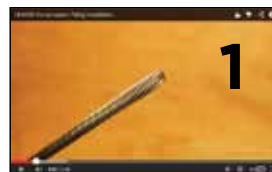

HI-MOD COMPRESSION FITTINGS CONE CONFIGURATION CHART



Wire Ø	Wire Type	Body Code	Cone P/N	Cone Color	Cone Length	Ident. Rings	Crown Ring P/N
1/8" or 3mm	1x19	03	CTC18	Red	0.551	0	CTCR18
5/32" or 4mm	1x19	04	CTC532	Blue	0.787	0	CTCR532
3/16" or 5mm	1x19	05	CTC316	Green	0.933	0	CTCR316
7/32"	1x19	05	CTC732	Black	0.874	0	CTCR732
6mm	1x19	06	CTCM6	Red	1.106	0	CTCR14
1/4"	1x19	06	CTC14	Blue	1.106	0	CTCR14
9/32" or 7mm	1x19	07	CTC932	Green	1.283	0	CTCR932
5/16" or 8mm	1x19	08	CTC516	Black	1.571	0	CTCR516
3/8"	1x19	10	CTC38	Blue	1.886	0	CTCR38
10mm	1x19	10	CTCM10	Red	1.874	0	CTCR38
12mm	1x19	12	CTCM12	Black	2.209	0	CTCR12
7/16"	1x19	10	CTC716	Green	1.874	0	CTCR38
1/2"	1x19	12	CTC12	Red	2.209	0	CTCR12
9/16" or 14mm	1x19	14	CTC916	Blue	2.550	0	CTCR916
5/8" or 16mm	1x19	16	CTC58	Green	3.150	0	CTCR58
3/4" or 19mm	1x19	19	CTC34	Black	3.413	0	CTCR34
7/8" or 22mm	1x19	22	CTC78	Red	3.913	0	CTCR78
1" or 26mm	1x19	26	CTC1	Blue	4.606	0	CTCR1

CS - KOS Compact Strand / D - Bridon Dyform

3mm	1x7	03	CTC18-7	Red	0.551	0	CTCR18
4mm	1x7	04	CTC532-7	Blue	0.787	0	CTCR532
5mm	1x19	05	CTC316	Green	0.933	0	CTCRM5-D
6mm	1x19	06	CTCM6	Red	1.106	0	CTCRM6-D
7mm	1x19	07	CTC932	Green	1.283	0	CTCRM7-D
8mm	1x19	08	CTC516	Black	1.571	0	CTCRM8-D
10mm	1x19	10	CTCM10	Red	1.874	0	CTCRM10-D
12mm*	1x19	12	CTCM12	Black	2.209	0	CTCRM12-D
12mm	1x19	12	CTCM12-CS	Red	2.209	0	CTCRM12-D
14mm	D - 1x25	14	CTCM14-D	Blue	2.543	2	CTCRM14-D
14mm	CS - 1x36	14	CTCM14-CS	No Color	2.235	2	CTCRM14-CS
16mm	D - 1x25	16	CTCM16-D	Green	3.138	2	CTCRM16-D
16mm	CS - 1x36	16	CTCM16-CS	No Color	3.090	2	CTCRM16-CS
19mm	D - 1x31	19	CTCM19-D	Black	3.413	2	CTCRM19-D
19mm	CS - 1x31	19	CTCM19-CS	Black	3.355	2	CTCRM19-CS
19mm	CS - 1x36	19	CTCM19-CS1x36	No Color	2.630	0	CTCRM19-CS1x36

7 Strand - Includes 1x7, 7x7, 7x19

1/8" or 3mm	7 Strand	03	CTC18-7	Red	0.512	1	CTCR18
5/32" or 4mm	7 Strand	04	CTC532-7	Blue	0.709	1	CTCR532
3/16" or 5mm	7 Strand	05	CTC316-7	Green	0.886	1	CTCR316
7/32"	7 Strand	05	CTC732-7	Black	0.886	1	CTCR732
6mm	7 Strand	06	CTCM6-7	Red	1.063	1	CTCR14-7
1/4"	7 Strand	06	CTC14-7	Blue	1.063	1	CTCR14-7
9/32" or 7mm	7 Strand	07	CTC932-7	Green	1.181	1	CTCR932-7
5/16" or 8mm	7 Strand	08	CTC516-7	Black	1.461	1	CTCR516-7
3/8"	7 Strand	10	CTC38-7	Blue	1.764	1	CTCR38-7
10mm	7 Strand	10	CTCM10-7	Red	1.764	1	CTCR38-7
7/16"	7 Strand	10	CTC716-7	Green	1.768	1	CTCR38-7
1/2" or 12mm	7 Strand	12	CTC12-7	Black	2.181	1	CTCR12-7
9/16" or 14mm	7 Strand	14	CTC916-7	Red	2.504	1	CTCR916-7

*NOTE: There are instances where 12mm Compact Strand does not allow for adequate thread engagement. In this case, the cone is to be substituted with part # CTC12.

Hi-MOD COMPRESSION EYES

316 Stainless Steel

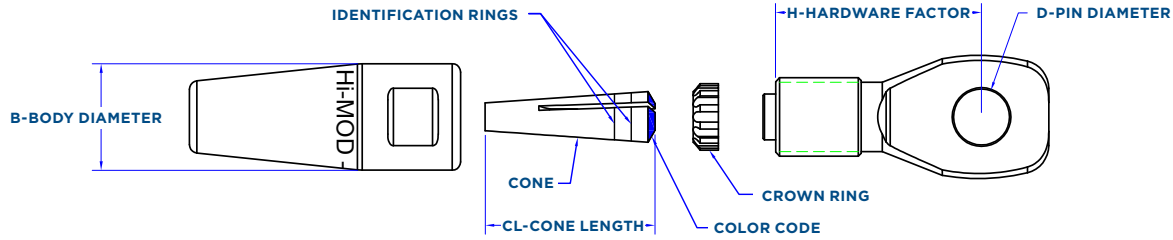

Strand Configuration Part # Imperial Wire Sizes

1x19	7x7 or 7x19	Wire Ø	D-Pin Ø	H-Hardware Factor	HT-Head Thickness	Weight lbs.
14CTE18	14CTE18-7	1/8"	1/4"	7/8"	3/16"	0.04
516CTE532	516CTE532-7	5/32"	5/16"	1 1/16"	1/4"	0.08
38CTE316	38CTE316-7	3/16"	3/8"	1 5/16"	5/16"	0.14
38CTE732	38CTE732-7	7/32"	3/8"	1 1/2"	3/8"	0.14
716CTE732	716CTE732-7	7/32"	7/16"	1 1/2"	3/8"	0.19
38CTE14	38CTE14-7	1/4"	3/8"	1 3/8"	3/8"	0.21
716CTE14	716CTE14-7	1/4"	7/16"	1 9/16"	3/8"	0.20
12CTE14	12CTE14-7	1/4"	1/2"	1 5/8"	7/16"	0.28
12CTE932	12CTE932-7	9/32"	1/2"	1 3/4"	7/16"	0.37
12CTE516	12CTE516-7	5/16"	1/2"	1 15/16"	1/2"	0.52
916CTE516	916CTE516-7	5/16"	9/16"	2"	1/2"	0.60
58CTE516	58CTE516-7	5/16"	5/8"	2 1/4"	9/16"	0.69
58CTE38	58CTE38-7	3/8"	5/8"	2 5/16"	9/16"	0.96
34CTE716	34CTE716-7	7/16"	3/4"	2 5/8"	11/16"	1.23
34CTE12	34CTE12-7	1/2"	3/4"	3 1/8"	11/16"	1.96
78CTE12	78CTE12-7	1/2"	7/8"	3 1/8"	7/8"	2.13
78CTE916	78CTE916-7	9/16"	7/8"	3 3/8"	7/8"	2.87
1CTE916	1CTE916-7	9/16"	1"	3 3/4"	15/16"	3.36
1CTE58	1CTE58-7	5/8"	1"	3 7/8"	15/16"	4.02
118CTE34	118CTE34-7	3/4"	1 1/8"	3 5/8"	1 1/16"	4.66
114CTE78	114CTE78-7	7/8"	1 1/4"	4 1/4"	1 1/4"	6.77
138CTE1	138CTE1-7	1"	1 3/8"	5 11/16"	1 5/16"	12.45

Strand Configuration Part # Metric Wire Sizes

1x19	7x7 or 7x19	Compact Strand Dyform	Wire Ø	D-Pin Ø	H-Hardware Factor	HT-Head Thickness	Weight lbs.
14CTEM03	14CTEM03-7	-	3mm	1/4"	7/8"	3/16"	0.04
516CTEM04	516CTEM04-7	-	4mm	5/16"	1 1/16"	1/4"	0.08
38CTEM05	38CTEM05-7	38CTEM05-D	5mm	3/8"	1 5/16"	5/16"	0.14
38CTEM06	38CTEM06-7	38CTEM06-D	6mm	3/8"	1 3/8"	3/8"	0.21
716CTEM06	716CTEM06-7	716CTEM06-D	6mm	7/16"	1 9/16"	3/8"	0.20
12CTEM06	12CTEM06-7	12CTEM06-D	6mm	1/2"	1 5/8"	7/16"	0.28
12CTEM07	12CTEM07-7	12CTEM07-D	7mm	1/2"	1 3/4"	7/16"	0.37
12CTEM08	12CTEM08-7	12CTEM08-D	8mm	1/2"	1 5/16"	1/2"	0.52
916CTEM08	916CTEM08-7	916CTEM08-D	8mm	9/16"	2"	1/2"	0.60
58CTEM08	58CTEM08-7	58CTEM08-D	8mm	5/8"	2 1/4"	9/16"	0.69
58CTEM10	58CTEM10-7	58CTEM10-D	10mm	5/8"	2 5/16"	9/16"	0.96
34CTEM12	34CTEM12-7	34CTEM12-D	12mm	3/4"	3 1/8"	11/16"	1.96
-	-	34CTEM12-CS	12mm	3/4"	3 1/8"	11/16"	1.96
78CTEM14	-	78CTEM14-D	14mm	7/8"	3 3/8"	7/8"	2.87
-	-	78CTEM14-CS	14mm	7/8"	3 3/8"	7/8"	2.87
1CTEM14	-	1CTEM14-D	14mm	1"	3 7/16"	7/8"	3.75
-	-	1CTEM14-CS	14mm	1"	3 7/16"	7/8"	3.75
1CTEM16	-	1CTEM16-D	16mm	1"	3 7/8"	15/16"	4.02
-	-	1CTEM16-CS	16mm	1"	3 7/8"	15/16"	4.02
118CTEM19	-	118CTEM19-D	19mm	1 1/8"	3 5/8"	1 1/16"	4.66
-	-	118CTEM19-CS	19mm	1 1/8"	3 5/8"	1 1/16"	4.66
114CTEM22	-	114CTEM22-D	22mm	1 1/4"	4 1/4"	1 1/4"	6.77
-	-	114CTEM22-CS	22mm	1 1/4"	4 1/4"	1 1/4"	6.77
138CTEM26	-	138CTEM26-D	26mm	1 3/8"	5 11/16"	1 5/16"	12.45
-	-	138CTEM26-CS	26mm	1 3/8"	5 11/16"	1 5/16"	12.45

Hi-MOD COMPRESSION STUDS

316 Stainless Steel

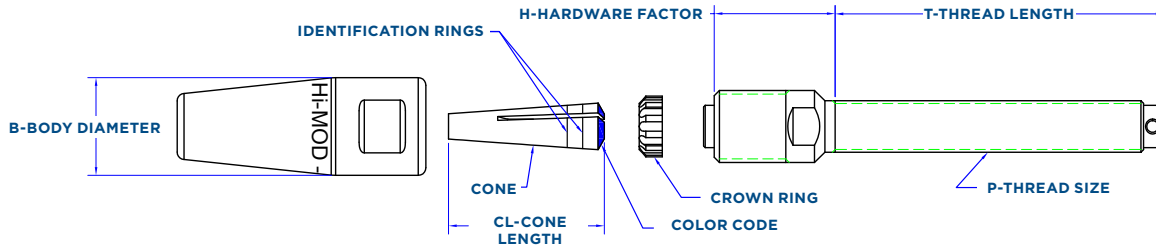

Strand Configuration Part #

Imperial Wire Sizes

1x19	7x7 or 7x19	Wire Ø	P-Thread	H-Hardware Factor	T-Thread Length	Weight lbs.
14CTS18	14CTS18-7	1/8"	1/4-28	5/8"	2"	0.05
14CTS532	14CTS532-7	5/32"	1/4-28	11/16"	2"	0.07
516CTS532	516CTS532-7	5/32"	5/16-24	7/8"	2 1/4"	0.09
516CTS316	516CTS316-7	3/16"	5/16-24	1"	2 1/4"	0.14
38CTS316	38CTS316-7	3/16"	3/8-24	7/8"	2 5/8"	0.17
38CTS732	38CTS732-7	7/32"	3/8-24	7/8"	2 5/8"	0.17
716CTS732	716CTS732-7	7/32"	7/16-20	1"	2 7/8"	0.20
38CTS14	38CTS14-7	1/4"	3/8-24	1 1/8"	2 5/8"	0.24
716CTS14	716CTS14-7	1/4"	7/16-20	1 1/8"	2 7/8"	0.28
12CTS14	12CTS14-7	1/4"	1/2-20	1 1/16"	3 1/2"	0.35
12CTS932	12CTS932-7	9/32"	1/2-20	1 1/8"	3 1/2"	0.43
12CTS516	12CTS516-7	5/16"	1/2-20	1 1/2"	3 1/2"	0.62
58CTS516	58CTS516-7	5/16"	5/8-18	1 1/2"	3 3/4"	0.75
58CTS38	58CTS38-7	3/8"	5/8-18	1 3/8"	3 3/4"	1.02
34CTS38	34CTS38-7	3/8"	3/4-18	1 1/2"	4 5/8"	1.24
34CTS716	34CTS716-7	7/16"	3/4-16	1 1/2"	4 5/8"	1.22
34CTS12	34CTS12-7	1/2"	3/4-16	2"	4 5/8"	1.95
78CTS12	78CTS12-7	1/2"	7/8-14	2"	5 1/2"	2.85
78CTS916	78CTS916-7	9/16"	7/8-14	2 1/8"	5 1/2"	2.87
1CTS58	1CTS58-7	5/8"	1.0-12	2 3/4"	6 1/4"	4.35
118CTS34	118CTS34-7	3/4"	1 1/8-12	2 1/2"	6 3/4"	5.27
114CTS78	114CTS78-7	7/8"	1 1/4-12	2 7/8"	7 3/4"	7.36
138CTS1	138CTS1-7	1"	1 3/8-12	3 5/8"	8 1/2"	14.5

Strand Configuration Part #

Metric Wire Sizes

1x19	7x7 or 7x19	Compact Strand Dyform	Wire Ø	P-Thread	H-Hardware Factor	T-Thread Length	Weight lbs.
14CTSM03	14CTSM03-7	-	3mm	1/4-28	5/8"	2"	0.05
14CTSM04	14CTSM04-7	-	4mm	1/4-28	11/16"	2"	0.06
516CTSM04	516CTSM04-7	-	4mm	5/16-24	7/8"	2 1/4"	0.09
516CTSM05	516CTSM05-7	516CTSM05-D	5mm	5/16-24	1"	2 1/4"	0.14
38CTSM05	38CTSM05-7	38CTSM05-D	5mm	3/8-24	7/8"	2 5/8"	0.17
38CTSM06	38CTSM06-7	38CTSM06-D	6mm	3/8-24	1 1/8"	2 5/8"	0.24
716CTSM06	716CTSM06-7	716CTSM06-D	6mm	7/16-20	1 1/8"	2 7/8"	0.28
12CTSM06	12CTSM06-7	12CTSM06-D	6mm	1/2-20	1 1/16"	3 1/2"	0.35
12CTSM07	12CTSM07-7	12CTSM07-D	7mm	1/2-20	1 1/8"	3 1/2"	0.43
12CTSM08	12CTSM08-7	12CTSM08-D	8mm	1/2-20	1 1/2"	3 1/2"	0.62
58CTSM08	58CTSM08-7	58CTSM08-D	8mm	5/8-18	1 1/2"	3 3/4"	0.75
58CTSM10	58CTSM10-7	58CTSM10-D	10mm	5/8-18	1 3/8"	3 3/4"	1.02
34CTSM10	34CTSM10-7	34CTSM10-D	10mm	3/4-16	1 1/2"	4 5/8"	1.24
34CTSM12	34CTSM12-7	34CTSM12-D	12mm	3/4-16	2"	4 5/8"	1.95
-	-	34CTSM12-CS	12mm	3/4-16	2"	4 5/8"	1.95
78CTSM12	78CTSM12-7	78CTSM12-D	12mm	7/8-14	2"	5 1/2"	2.85
-	-	78CTSM12-CS	12mm	7/8-14	2"	5 1/2"	2.85
78CTSM14	78CTSM14-7	78CTSM14-D	14mm	7/8-14	2 1/8"	5 1/2"	2.87
-	-	78CTSM14-CS	14mm	7/8-14	2 1/8"	5 1/2"	2.87
1CTSM16	1CTSM16-7	1CTSM16-D	16mm	1.0-12	2 3/4"	6 1/4"	4.35
-	-	1CTSM16-CS	16mm	1.0-12	2 3/4"	6 1/4"	4.35
118CTSM19	-	118CTSM19-D	19mm	1 1/8-12	2 1/2"	6 3/4"	5.27
-	-	118CTSM19-CS	19mm	1 1/8-12	2 1/2"	6 3/4"	5.27
114CTSM22	-	114CTSM22-D	22mm	1 1/4-12	2 7/8"	7 3/4"	7.36
-	-	114CTSM22-CS	22mm	1 1/4-12	2 7/8"	7 3/4"	7.36
138CTSM26	-	138CTSM26-D	26mm	1 3/8-12	3 5/8"	8 1/2"	14.5
-	-	138CTSM26-CS	26mm	1 3/8-12	3 5/8"	8 1/2"	14.5

Hi-MOD COMPRESSION TOGGLES

316 Stainless Steel

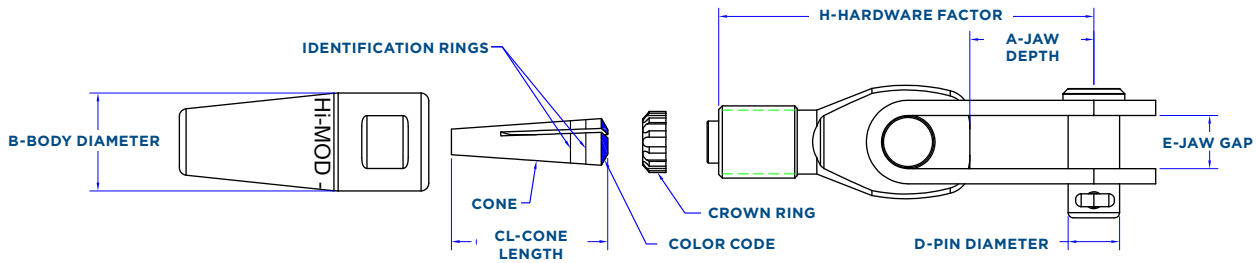

Strand Configuration Part # Imperial Wire Sizes

1x19	7x7 or 7x19	Wire Ø	D-Pin Ø	A-Jaw Depth	E-Jaw Gap	H-Hardware Factor	Weight lbs.
14CTT18	14CTT18-7	1/8"	1/4"	9/16"	1/4"	1 3/4"	0.10
516CTT532	516CTT532-7	5/32"	5/16"	5/8"	5/16"	2 1/32"	0.17
38CTT316	38CTT316-7	3/16"	3/8"	3/4"	3/8"	2 9/16"	0.30
38CTT732	38CTT732-7	7/32"	3/8"	3/4"	3/8"	2 9/16"	0.30
38CTT14	38CTT14-7	1/4"	3/8"	3/4"	3/8"	2 5/8"	0.36
12CTT14	12CTT14-7	1/4"	1/2"	1 1/8"	1/2"	3 5/16"	0.63
12CTT932	12CTT932-7	9/32"	1/2"	1 1/8"	1/2"	3 7/16"	0.72
12CTT516	12CTT516-7	5/16"	1/2"	1 1/8"	1/2"	3 5/8"	0.88
916CTT516	916CTT516-7	5/16"	9/16"	1 1/4"	9/16"	4"	2.35
58CTT516	58CTT516-7	5/16"	5/8"	1 1/4"	5/8"	4 1/2"	1.41
58CTT38	58CTT38-7	3/8"	5/8"	1 1/4"	5/8"	4 9/16"	1.68
34CTT716	34CTT716-7	7/16"	3/4"	1 7/8"	3/4"	5 13/16"	2.54
34CTT12	34CTT12-7	1/2"	3/4"	1 7/8"	3/4"	5 13/16"	3.01
78CTT916	78CTT916-7	9/16"	7/8"	2 7/8"	7/8"	7 3/8"	5.54
1CTT58	1CTT58-7	5/8"	1"	2 5/8"	1"	7 1/2"	7.35

Strand Configuration Part # Metric Wire Sizes

1x19	7x7 or 7x19	Compact Strand Dyform	Wire Ø	D-Pin Ø	A-Jaw Depth	E-Jaw Gap	H-Hardware Factor	Weight lbs.
14CTTM03	14CTTM03-7	-	3mm	1/4"	9/16"	1/4"	1 3/4"	0.10
516CTTM04	516CTTM04-7	-	4mm	5/16"	5/8"	5/16"	2 1/32"	0.17
38CTTM05	38CTTM05-7	38CTTM05-D	5mm	3/8"	3/4"	3/8"	2 9/16"	0.30
38CTTM06	38CTTM06-7	38CTTM06-D	6mm	3/8"	3/4"	3/8"	2 9/16"	0.36
12CTTM06	12CTTM06-7	12CTTM06-D	6mm	1/2"	3/4"	1/2"	3 5/16"	0.63
12CTTM07	12CTTM07-7	12CTTM07-D	7mm	1/2"	1 1/8"	1/2"	3 7/16"	0.72
12CTTM08	12CTTM08-7	12CTTM08-D	8mm	1/2"	1 1/8"	1/2"	3 5/8"	0.88
916CTTM08	916CTTM08-7	916CTTM08-D	8mm	9/16"	1 1/8"	9/16"	4 1/2"	2.35
58CTTM08	58CTTM08-7	58CTTM08-D	8mm	5/8"	1 1/4"	5/8"	4 1/2"	1.41
58CTTM10	58CTTM10-7	58CTTM10-D	10mm	5/8"	1 1/4"	5/8"	4 9/16"	1.68
34CTTM12	34CTTM12-7	34CTTM12-D	12mm	3/4"	1 7/8"	3/4"	4 9/16"	3.01
-	-	34CTTM12-CS	12mm	3/4"	1 7/8"	3/4"	4 9/16"	3.01
78CTTM14	-	78CTTM14-D	14mm	7/8"	2 7/8"	7/8"	7 3/8"	5.54
-	-	78CTTM14-CS	14mm	7/8"	2 7/8"	7/8"	7 3/8"	5.54
1CTTM16	-	1CTTM16-D	16mm	1"	2 7/8"	1"	7 1/2"	7.35
-	-	1CTTM16-CS	16mm	1"	2 5/8"	1"	7 1/2"	7.35

Hi-MOD COMPRESSION FORKS

316 Stainless Steel

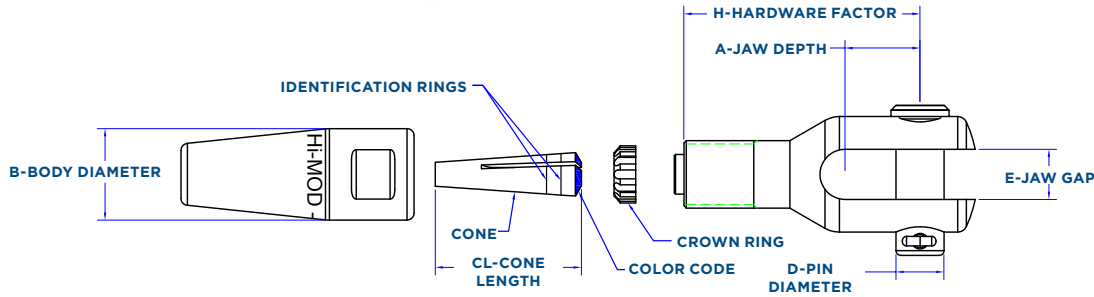

Strand Configuration Part # Imperial Wire Sizes

1x19	7x7 or 7x19	Wire Ø	D-Pin Ø	A-Jaw Depth	E-Jaw Gap	H-Hardware Factor	Weight lbs.
14CTF18	14CTF18-7	1/8"	1/4"	1/2"	1/4"	1 1/4"	0.06
516CTF532	516CTF532-7	5/32"	5/16"	21/32"	5/16"	1 1/2"	0.13
38CTF316	38CTF316-7	3/16"	3/8"	3/4"	3/8"	1 11/16"	0.23
38CTF732	38CTF732-7	7/32"	3/8"	3/4"	3/8"	1 11/16"	0.23
716CTF14	716CTF14-7	1/4"	7/16"	7/8"	7/16"	1 15/16"	0.37
12CTF14	12CTF14-7	1/4"	1/2"	1"	1/2"	2 1/8"	0.46
12CTF932	12CTF932-7	9/32"	1/2"	1"	1/2"	2 1/8"	0.56
12CTF516	12CTF516-7	5/16"	1/2"	1"	1/2"	2 1/8"	0.72
916CTF516	916CTF516-7	5/16"	9/16"	1 1/8"	9/16"	2 3/4"	0.99
58CTF516	58CTF516-7	5/16"	5/8"	1 1/4"	5/8"	2 3/4"	1.09
58CTF38	58CTF38-7	3/8"	5/8"	1 1/4"	5/8"	3"	1.40
34CTF716	34CTF716-7	7/16"	3/4"	1 1/2"	3/4"	3 3/8"	1.97
34CTF12	34CTF12-7	1/2"	3/4"	1 1/2"	3/4"	3 5/8"	2.70
78CTF916	78CTF916-7	9/16"	7/8"	1 3/4"	7/8"	4 1/8"	3.23
1CTF58	1CTF58-7	5/8"	1"	1 15/16"	1"	4 7/8"	4.61
118CTF34	118CTF34-7	3/4"	1 1/8"	2 9/32"	1 1/8"	5 1/4"	6.28
114CTF78	114CTF78-7	7/8"	1 1/4"	2 1/2"	1 1/4"	5 3/4"	8.75
138CTF1	138CTF1-7	1"	1 3/8"	2 3/4"	1 3/8"	6 1/2"	14.25

Strand Configuration Part # Metric Wire Sizes

1x19	7x7 or 7x19	Compact Strand Dyform	Wire Ø	D-Pin Ø	A-Jaw Depth	E-Jaw Gap	H-Hardware Factor	Weight lbs.
14CTFM03	14CTFM03-7	-	3mm	1/4"	1/2"	1/4"	1 1/4"	0.06
516CTFM04	516CTFM04-7	-	4mm	5/16"	21/32"	5/16"	1 1/2"	0.13
38CTFM05	38CTFM05-7	38CTFM05-D	5mm	3/8"	3/4"	3/8"	1 11/16"	0.23
716CTFM06	716CTFM06-7	716CTFM06-D	6mm	7/16"	7/8"	7/16"	1 15/16"	0.37
12CTFM07	12CTFM07-7	12CTFM07-D	7mm	1/2"	1"	1/2"	2 1/8"	0.56
12CTFM08	12CTFM08-7	12CTFM08-D	8mm	1/2"	1"	1/2"	2 1/8"	0.72
916CTFM08	916CTFM08-7	916CTFM08-D	8mm	9/16"	1 1/8"	9/16"	2 3/4"	0.99
58CTFM08	58CTFM08-7	58CTFM08-D	8mm	5/8"	1 1/4"	9/16"	2 3/4"	1.09
58CTFM10	58CTFM10-7	58CTFM10-D	10mm	5/8"	1 1/4"	5/8"	3"	1.40
34CTFM12	34CTFM12-7	34CTFM12-D	12mm	3/4"	1 1/2"	3/4"	3 5/8"	2.70
-	-	34CTFM12-CS	12mm	3/4"	1 1/2"	3/4"	3 5/8"	2.70
78CTFM14	-	78CTFM14-D	14mm	7/8"	1 3/4"	7/8"	4 1/8"	3.23
-	-	78CTFM14-CS	14mm	7/8"	1 3/4"	7/8"	4 1/8"	3.23
1CTFM16	-	1CTFM16-D	16mm	1"	1 15/16"	1"	4 7/8"	4.61
-	-	1CTFM16-CS	16mm	1"	1 15/16"	1"	4 7/8"	4.61
118CTFM19	-	118CTFM19-D	19mm	1 1/8"	2 9/32"	1 1/8"	5 1/4"	6.28
-	-	118CTFM19-CS	19mm	1 1/8"	2 9/32"	1 1/8"	5 1/4"	6.28
114CTFM22	-	114CTFM22-D	22mm	1 1/4"	2 1/2"	1 1/4"	5 3/4"	8.75
-	-	114CTFM22-CS	22mm	1 1/4"	2 1/2"	1 1/4"	5 3/4"	8.75
138CTFM26	-	138CTFM26-D	26mm	1 3/8"	2 3/4"	1 3/8"	6 1/2"	14.25
-	-	138CTFM26-CS	26mm	1 3/8"	2 3/4"	1 3/8"	6 1/2"	14.25

Hi-MOD COMPRESSION EXTENDERS

316 Stainless Steel

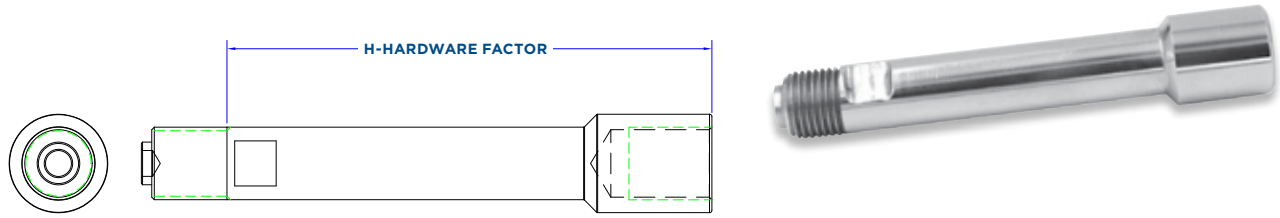

Imperial Wire Sizes

Part #	Wire Ø	H-Hardware Factor	Weight lbs.
CTX18	1/8"	1 3/4"	0.04
CTX532	5/32"	2 1/4"	0.08
CTX316	3/16"	2 7/8"	0.15
CTX732	7/32"	2 7/8"	0.15
CTX14	1/4"	3 1/4"	0.28
CTX932	9/32"	3 7/8"	0.42
CTX516	5/16"	4 1/2"	0.68
CTX38	3/8"	5 5/8"	1.15
CTX716	7/16"	5 5/8"	1.15
CTX12	1/2"	6 3/4"	2.25
CTX916	9/16"	8"	3.34
CTX58	5/8"	9"	4.66

Metric Wire Sizes

Part #	Wire Ø	H-Hardware Factor	Weight lbs.
CTXM03	3mm	1 3/4"	0.04
CTXM04	4mm	2 1/4"	0.08
CTXM05	5mm	2 7/8"	0.15
CTXM06	6mm	3 1/4"	0.28
CTXM07	7mm	3 7/8"	0.42
CTXM08	8mm	4 1/2"	0.68
CTXM10	10mm	5 5/8"	1.15
CTXM12	12mm	6 3/4"	2.25
CTXM14	14mm	8"	3.34
CTXM16	16mm	9"	4.66

Hi-MOD COMPRESSION SPLICE LINKS

316 Stainless Steel

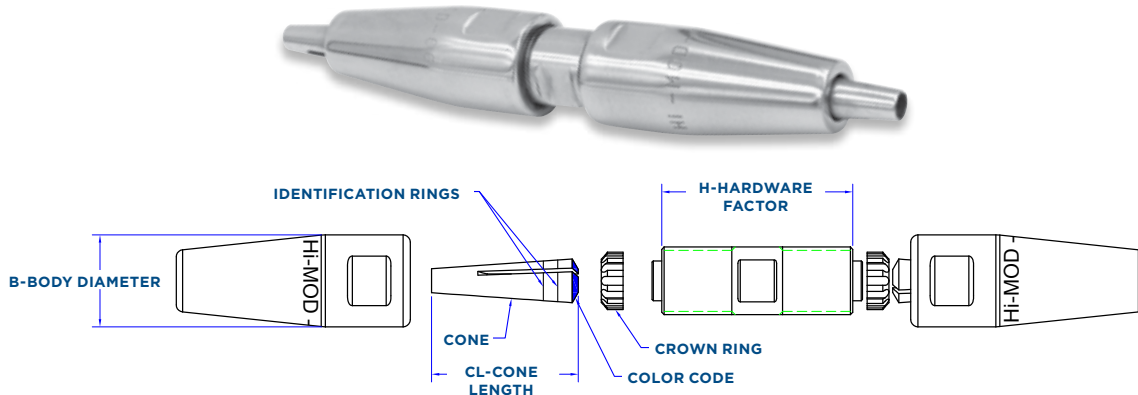

1x19 Strand Imperial Wire Sizes

Part #	Wire Ø	H-Hardware Factor	Weight lbs.
CTL18	1/8"	1"	0.06
CTL532	5/32"	1"	0.10
CTL316	3/16"	1 5/16"	0.19
CTL732	7/32"	1 5/16"	0.19
CTL14	1/4"	1 3/8"	0.32
CTL932	9/32"	1 5/8"	0.50
CTL516	5/16"	2 1/8"	0.86
CTL38	3/8"	2 1/2"	1.39
CTL716	7/16"	2 1/2"	1.35
CTL12	1/2"	2 7/8"	2.65
CTL916	9/16"	3 1/4"	4.08
CTL58	5/8"	3 3/4"	5.70

1x19 Strand Metric Wire Sizes

Part #	Wire Ø	H-Hardware Factor	Weight lbs.
CTLM03	3mm	1"	0.06
CTLM04	4mm	1"	0.10
CTLM05	5mm	1 5/16"	0.19
CTLM06	6mm	1 3/8"	0.32
CTLM07	7mm	1 5/8"	0.50
CTLM08	8mm	2 1/8"	0.86
CTLM10	10mm	2 1/2"	1.39
CTLM12	12mm	2 7/8"	2.65
CTLM14	14mm	3 1/4"	4.08
CTLM16	16mm	3 3/4"	5.70

NOTE: Imperial wire sizes available in 7-strand configurations by adding -7 to the Part #.

Metric wire sizes also available in Compact Strand, Dyform, and 7-strand configurations by adding -CS, -D, or -7 to the Part #, respectively.

FAILSAFE BACKSTAY INSULATORS



The Failsafe Insulator is engineered with an internal ball-socket in the main body that threads onto the connecting end fitting. The internal retaining nut is insulated from the stainless steel body by a Tufnol™ socket, preventing electrical transference to the insulator body or opposite terminal. Should, for any reason, the Tufnol™ be compromised, the nut will bottom out against the stainless housing. While the backstay will loosen, the insulating studs will remain attached to the insulator body. This allows the rig to be re-tensioned until a repair can be made.

The design of the insulators allows for numerous end fitting combinations. A permanent thread locking compound is applied to the center body coupling at

time of order. Check with your Hayn sales associate about applicable re-stocking fees.

Insulators with Swage style ends can be ordered "Un-Glued" in order to swage with a WireTeknik or equivalent roll swager. Please indicate "Un-Glued" at time of order by including the suffix "-DEMI" to the end of the part number. See the chart on the following page for applicable WireTeknik pulling attachments.

End fitting options include Swage, Compression, Eye, Toggle, and Fork. See listing below for possible combinations and part number conventions:

Insulator Part Number Conventions:

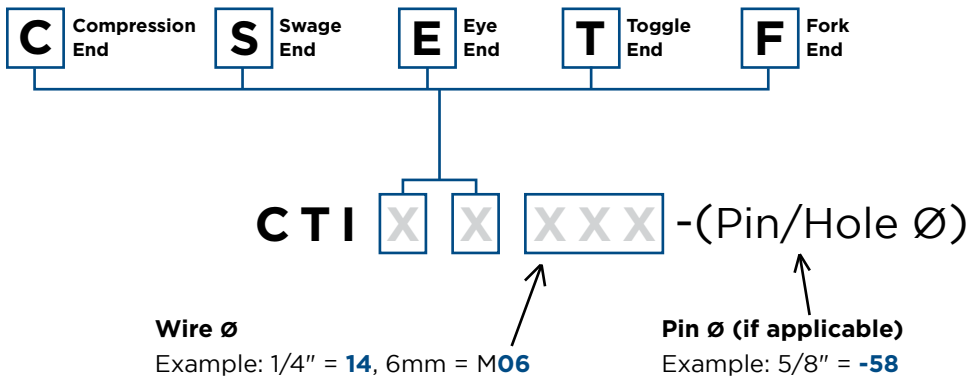

-DEMI pulling attachments for WireTeknik Swagers

Imperial Wire Ø	
Wire Size	Part #
3/16" to 1/4"	RIP716
9/32"	RIP12
5/16" to 3/8"	RIP58
7/16" to 1/2"	RIP34
Metric Wire Ø	
5mm to 6mm	RIP716
7mm	RIP12
8mm to 10mm	RIP58
12mm	RIP34

INSULATOR END FITTING CONFIGURATIONS

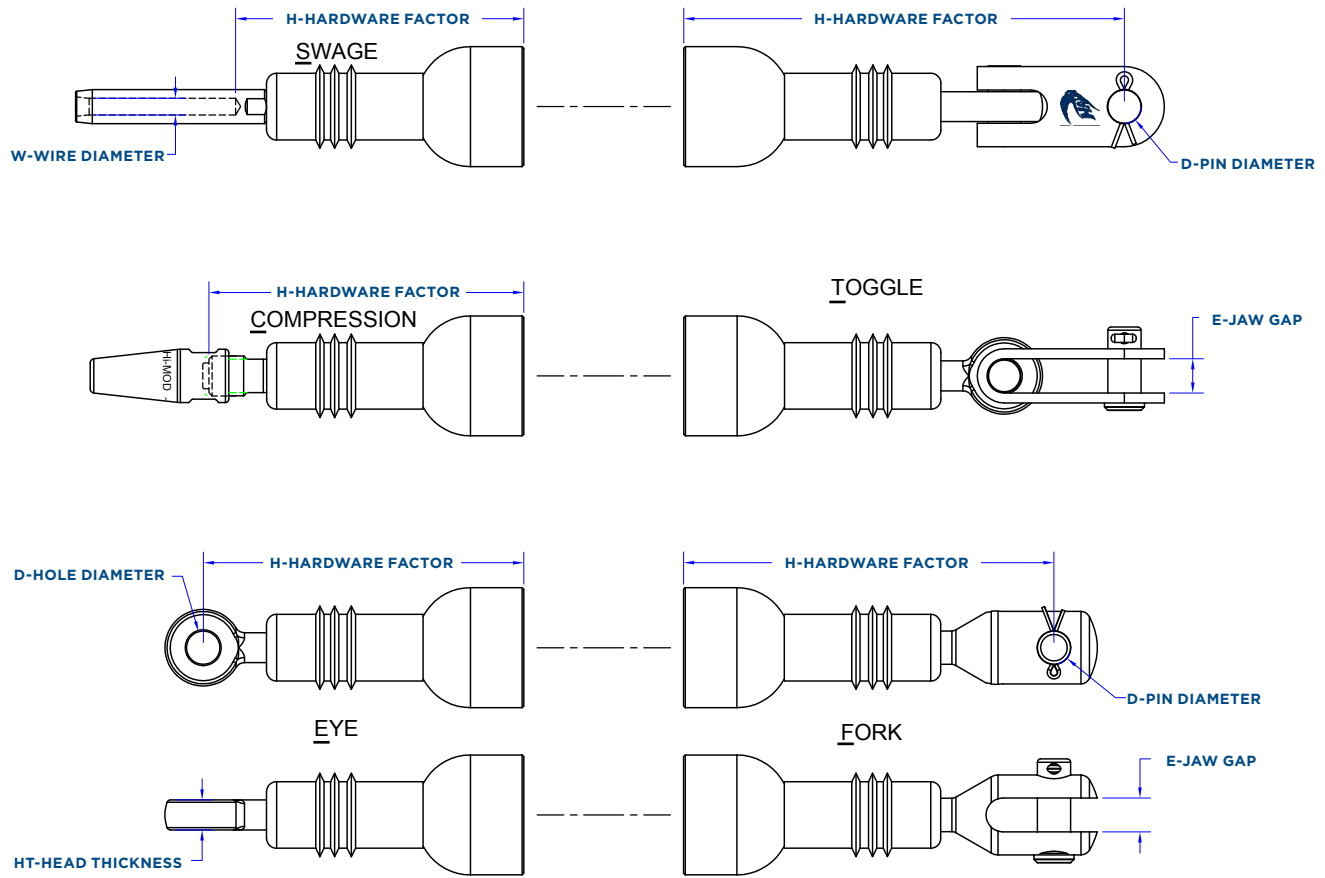

Insulators are assembled from two halves utilizing a center coupling. Any combination of halves detailed above is available. See page 42 for part number conventions. Permanent thread locker is used at the center joint to finalize the assembly process.

Imperial Wire Sizes Compression End Swage End Eye End Toggle End Fork End

W - Wire Ø	D - Pin/Hole Ø	H- Hardware Factor	H- Hardware Factor	H- Hardware Factor	H- Hardware Factor	H- Hardware Factor
3/16"	7/16"	4"	3 15/16"	4 1/8"	5 11/32"	4 3/4"
7/32"	7/16"	4"	3 15/16"	4 1/8"	5 7/8"	4 3/4"
1/4"	1/2"	4 1/4"	4"	4 1/2"	6 3/16"	4 3/4"
9/32"	1/2"	4 15/16"	4 1/2"	5"	6 11/16"	5 1/2"
5/16"	5/8"	5 1/4"	5 3/8"	6"	8 1/4"	6 7/8"
3/8"	5/8"	6 1/8"	5 3/8"	6"	8 1/4"	6 7/8"
1/2"	3/4"	7 9/16"	6 3/8"	7"	9 11/16"	8"
9/16"	7/8"	8 3/4"	7 11/16"	8 7/8"	12 7/8"	9 3/8"
5/8"	1"	10 1/8"	9 5/16"	9 3/8"	13 1/4"	10 3/4"

Metric Wire Sizes Compression End Swage End Eye End Toggle End Fork End

W - Wire Ø	D - Pin/Hole Ø	H- Hardware Factor	H- Hardware Factor	H- Hardware Factor	H- Hardware Factor	H- Hardware Factor
5mm	7/16"	4"	3 15/16"	4 1/8"	5 11/32"	4 3/4"
6mm	1/2"	4 1/4"	4"	4 1/2"	6 3/16"	4 3/4"
7mm	1/2"	4 15/16"	4 1/2"	5"	6 11/16"	5 1/2"
8mm	5/8"	5 5/16"	5 3/8"	6"	8 1/4"	6 7/8"
10mm	5/8"	5 7/8"	5 3/8"	6"	8 1/4"	6 7/8"
12mm	3/4"	7 9/16"	6 3/8"	7"	9 11/16"	8"
14mm	7/8"	8 3/4"	7 11/16"	8 7/8"	12 7/8"	9 3/8"
16mm	1"	10 1/8"	9 5/16"	9 3/8"	13 1/4"	10 3/4"

THREADED FITTINGS

- 45** Threaded Eye Toggle Jaws
- 46** Threaded T-Bolt Toggle Jaws
- 47** Threaded Eye Rods / Threaded Forks
- 48** Threaded Stemballs



THREADED EYE TOGGLE JAWS with retaining pin hole / Open Body Style

316 Stainless Steel

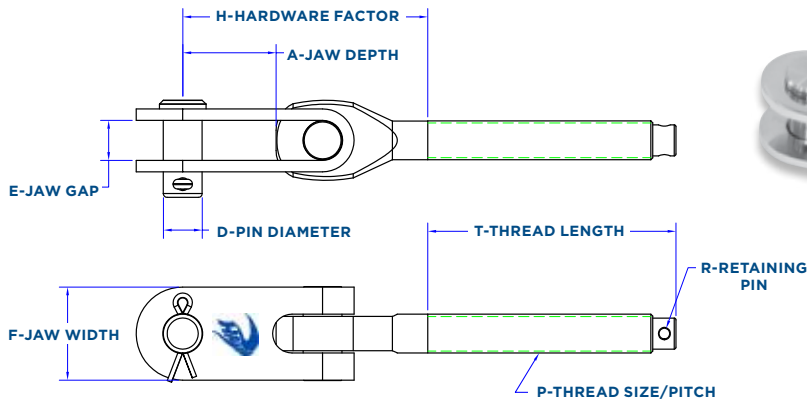

Left Hand Right Hand

Part #	Part #	P-Thread	D-Pin Ø	T-Thread Length	A-Jaw Depth	E-Jaw Gap	F-Jaw Width	H-Hardware Factor	R-Retaining Pin	Weight lbs.
14ETJLH	14ETJRH	1/4-28	1/4"	2 1/4"	9/16"	1/4"	21/32"	1 1/2"	1/16"	0.10
516ETJLH	516ETJRH	5/16-24	5/16"	2 3/8"	5/8"	5/16"	3/4"	1 13/16"	3/32"	0.17
38ETJLH	38ETJRH	3/8-24	3/8"	2 3/4"	3/4"	3/8"	57/64"	2 1/8"	3/32"	0.28
716ETJLH	716ETJRH	7/16-20	7/16"	2 1/2"	3/4"	7/16"	1 1/16"	2 1/4"	1/8"	0.39
12ETJLH	12ETJRH	1/2-20	1/2"	3 1/4"	1 1/8"	1/2"	1 5/32"	3"	1/8"	0.65
58ETJLH	58ETJRH	5/8-18	5/8"	4"	1 1/2"	5/8"	1 1/2"	3 15/16"	5/32"	1.27
34ETJLH	34ETJRH	3/4-16	3/4"	4 7/8"	1 7/8"	3/4"	1 7/8"	4 11/16"	3/16"	2.31
78ETJLH	78ETJRH	7/8-14	7/8"	5 1/2"	2 7/8"	7/8"	2 3/8"	5 7/8"	3/16"	4.01
1ETJLH	1ETJRH	1-12	1"	6 1/4"	2 5/8"	1"	2 1/2"	6 1/8"	3/16"	5.45
118ETJLH	-	1 1/8-12	1 1/8"	7"	2 3/4"	1 1/8"	2 3/4"	6 1/2"	1/4"	8.01
114ETJLH	-	1 1/4-12	1 1/4"	7 7/8"	3 7/8"	1 1/4"	3 1/4"	8 5/32"	1/4"	11.98
138ETJLH	-	1 3/8-12	1 3/8"	8 3/4"	4 5/16"	1 3/8"	4"	8 9/16"	1/4"	17.25

THREADED EYE TOGGLE JAWS w/o retaining pin / Closed Body Style

316 Stainless Steel

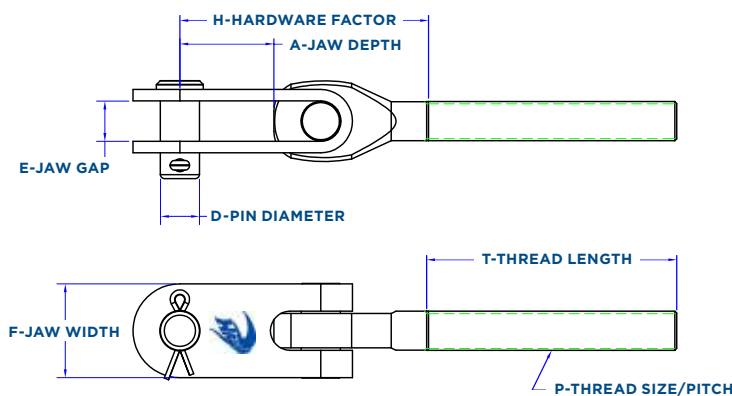

Left Hand Right Hand

Part #	Part #	P-Thread	D-Pin Ø	T-Thread Length	A-Jaw Depth	E-Jaw Gap	F-Jaw Width	H-Hardware Factor	Weight lbs.
14ETJLH-P	14ETJRH-P	1/4-28	1/4"	2 1/4"	9/16"	1/4"	21/32"	1 1/2"	0.10
516ETJLH-P	516ETJRH-P	5/16-24	5/16"	2 3/8"	5/8"	5/16"	3/4"	1 13/16"	0.17
38ETJLH-P	38ETJRH-P	3/8-24	3/8"	2 3/4"	3/4"	3/8"	57/64"	2 1/8"	0.28
12ETJLH-P	12ETJRH-P	1/2-20	1/2"	3 1/4"	1 1/8"	1/2"	1 5/32"	3"	0.65
58ETJLH-P	58ETJRH-P	5/8-18	5/8"	4"	1 1/2"	5/8"	1 1/2"	3 15/16"	1.27
34ETJLH-P	34ETJRH-P	3/4-16	3/4"	4 7/8"	1 7/8"	3/4"	1 7/8"	4 11/16"	2.31
78ETJLH-P	78ETJRH-P	7/8-14	7/8"	5 1/2"	2 7/8"	7/8"	2 3/8"	5 7/8"	4.01
1ETJLH-P	1ETJRH-P	1-12	1"	6 1/4"	2 5/8"	1"	2 1/2"	6 1/8"	5.45

THREADED T-BOLT TOGGLE JAWS with retaining pin hole / Open Body

316 Stainless Steel

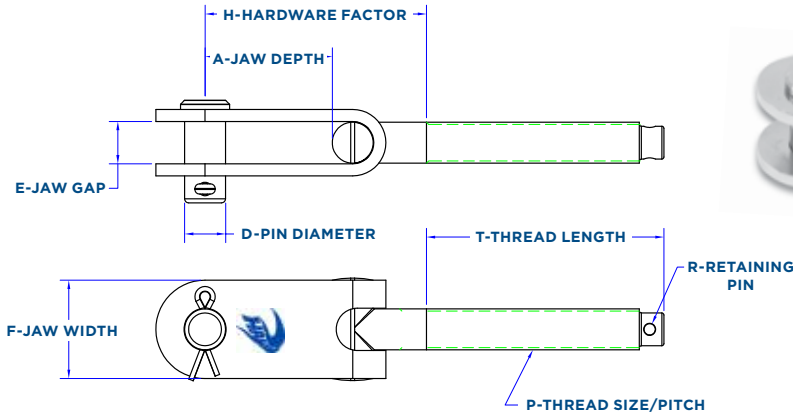

Left Hand Right Hand

Part #	Part #	P-Thread	D-Pin Ø	T-Thread Length	A-Jaw Depth	E-Jaw Gap	F-Jaw Width	H-Hardware Factor	R-Retaining Pin	Weight lbs.
14TJLH	14TJRH	1/4-28	1/4"	2 1/4"	3/4"	1/4"	21/32"	1 1/2"	1/16"	0.09
516TJLH	516TJRH	5/16-24	5/16"	2 1/2"	13/16"	5/16"	3/4"	1 1/2"	3/32"	0.14
38TJLH	38TJRH	3/8-24	3/8"	2 3/4"	1"	3/8"	57/64"	1 3/4"	3/32"	0.24
12TJLH	12TJRH	1/2-20	1/2"	3 1/4"	1 7/16"	1/2"	1 5/32"	2 5/16"	1/8"	0.54
58TJLH	58TJRH	5/8-18	5/8"	4"	1 15/16"	5/8"	1 1/2"	3"	5/32"	1.04
34TJLH	34TJRH	3/4-16	3/4"	5"	2 5/16"	3/4"	1 7/8"	4 3/16"	3/16"	2.01

THREADED T-BOLT TOGGLE JAWS w/o retaining pin hole / Closed Body Style

316 Stainless Steel

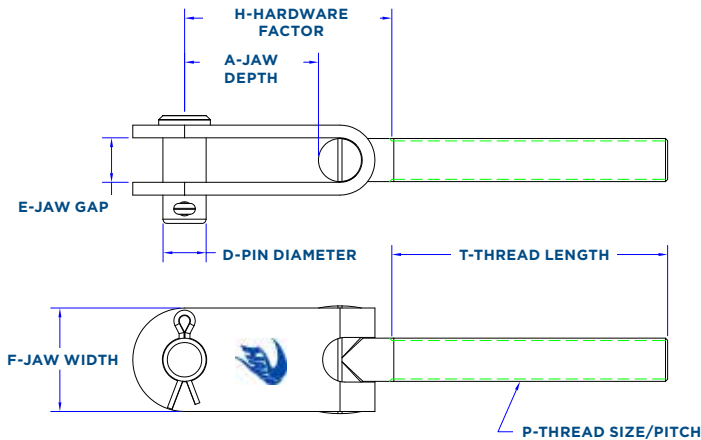

Left Hand Right Hand

Part #	Part #	P-Thread	D-Pin Ø	T-Thread Length	A-Jaw Depth	E-Jaw Gap	F-Jaw Width	H-Hardware Factor	Weight lbs.
14TJLH-P	14TJRH-P	1/4-28	1/4"	2 1/4"	3/4"	1/4"	21/32"	1 1/2"	0.09
516TJLH-P	516TJRH-P	5/16-24	5/16"	2 1/2"	13/16"	5/16"	3/4"	1 1/2"	0.14
38TJLH-P	38TJRH-P	3/8-24	3/8"	2 3/4"	1"	3/8"	57/64"	1 3/4"	0.24
12TJLH-P	12TJRH-P	1/2-20	1/2"	3 1/4"	1 7/16"	1/2"	1 5/32"	2 5/16"	0.54
58TJLH-P	58TJRH-P	5/8-18	5/8"	4"	1 15/16"	5/8"	1 1/2"	3"	1.04
34TJLH-P	34TJRH-P	3/4-16	3/4"	5"	2 5/16"	3/4"	1 7/8"	4 3/16"	2.01

THREADED EYE RODS

316 Stainless Steel

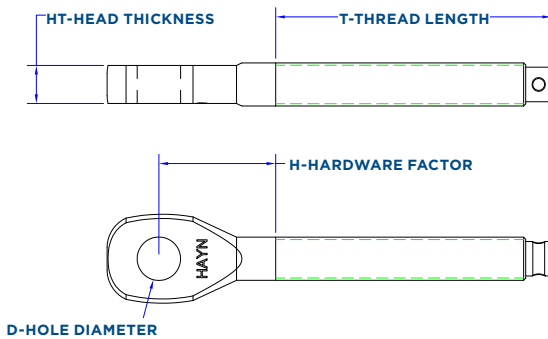

Left Hand		Right Hand	
Open Body Pin Hole	Closed Body w/o Pin Hole	Open Body Pin Hole	Closed Body w/o Pin Hole

Part #	Part #	Part #	Part #	Thread	D-Hole Ø	T-Thread Length	HT-Head Thickness	H-Hardware Factor	Weight lbs.
14ERLH	14ERLH-P	14ERRH	14ERRH-P	1/4-28	1/4"	2 1/4"	7/32"	9/16"	0.04
516ERLH	516ERLH-P	516ERRH	516ERRH-P	5/16-24	5/16"	2 3/8"	1/4"	13/16"	0.07
38ERLH	38ERLH-P	38ERRH	38ERRH-P	3/8-24	3/8"	2 3/4"	5/16"	7/8"	0.13
716ERLH	716ERLH-P	716ERRH	716ERRH-P	7/16-20	7/16"	2 3/4"	3/8"	1 1/16"	0.19
12ERLH	12ERLH-P	12ERRH	12ERRH-P	1/2-20	1/2"	3 1/4"	7/16"	1 3/8"	0.29
58ERLH	58ERLH-P	58ERRH	58ERRH-P	5/8-18	5/8"	4"	15/32"	1 11/16"	0.58
34ERLH	34ERLH-P	34ERRH	34ERRH-P	3/4-16	3/4"	4 7/8"	23/32"	2"	1.01
78ERLH	78ERLH-P	78ERRH	78ERRH-P	7/8-14	7/8"	5 1/2"	27/32"	1 15/16"	1.60
1ERLH	1ERLH-P	1ERRH	1ERRH-P	1-12	1"	6 1/4"	15/16"	2 5/16"	2.30
118ERLH	-	-	-	1 1/8-12	1 1/8"	7"	1 1/32"	2 1/2"	3.12
114ERLH	-	-	-	1 1/4-12	1 1/4"	7 7/8"	1 3/16"	2 3/4"	4.71
138ERLH	-	-	-	1 3/8-12	1 3/8"	8 3/4"	1 5/16"	2 5/8"	6.15

THREADED FORKS

316 Stainless Steel

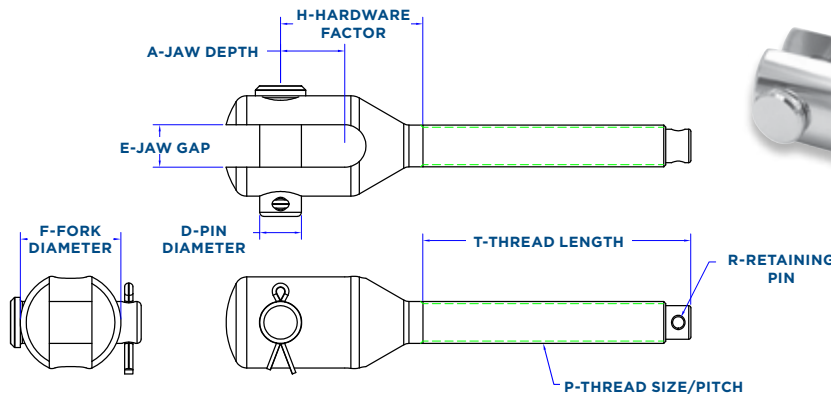

Left Hand		Right Hand	
-----------	--	------------	--

Part #	Part #	P-Thread	D-Pin Ø	T-Thread Length	A-Jaw Depth	E-Jaw Gap	F-Fork Ø	H-Hardware Factor	R-Retaining Pin	Weight lbs.
TF14LH	TF14RH	1/4-28	1/4"	2 1/4"	3/8"	1/4"	9/16"	7/8"	1/16"	0.06
TF516LH	TF516RH	5/16-24	5/16"	2 1/2"	7/16"	5/16"	23/32"	1 1/4"	3/32"	0.12
TF38LH	TF38RH	3/8-24	3/8"	2 7/8"	9/16"	3/8"	7/8"	1 7/16"	3/32"	0.21
TF12LH	TF12RH	1/2-20	1/2"	3 1/4"	11/16"	1/2"	1 1/8"	1 13/16"	1/8"	0.46
TF58LH	TF58RH	5/8-18	5/8"	4"	15/16"	5/8"	1 1/2"	2 1/8"	5/32"	1.02
TF34LH	TF34RH	3/4-16	3/4"	5"	1"	3/4"	1 7/8"	2 7/16"	3/16"	1.92
TF78LH	TF78RH	7/8-14	7/8"	6"	1 5/16"	7/8"	2 1/8"	2 3/4"	3/16"	2.79
TF1LH	TF1RH	1-12	1"	6 7/8"	1 15/32"	1"	2 1/2"	3 5/16"	3/16"	3.85
TF118LH	TF118RH	1 1/8-12	1 1/8"	7"	1 3/4"	1 1/8"	2 3/4"	4 1/8"	1/4"	6.50
TF114LH	TF114RH	1 1/4-12	1 1/4"	7 7/8"	1 15/16"	1 1/4"	3"	4 3/8"	1/4"	8.11
TF138LH	TF138RH	1 3/8-12	1 3/8"	8 5/8"	2 1/8"	1 3/8"	3 1/4"	4 7/8"	1/4"	10.56

THREADED STEMBALLS

316 Stainless Steel

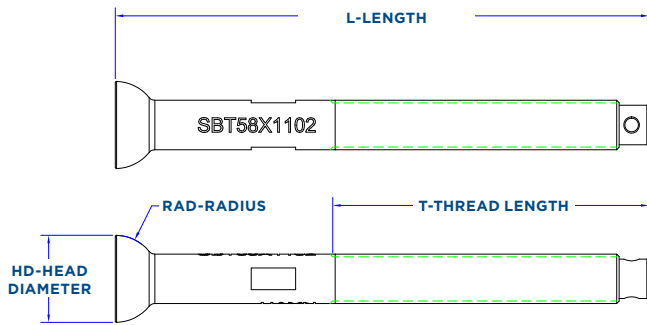

Left Hand

Part #	Thread	HD-Head Diameter	RAD-Radius	T-Thread Length	L-Length	Weight lbs.
SBT38LHX0.693	3/8-24	0.693"	0.436"	2 7/8"	4 1/8"	0.12
SBT12LHX1.000	1/2-20	1.0"	0.472"	3 1/4"	5 1/2"	0.33
SBT58LHX1.102	5/8-18	1.102"	0.551"	4"	6 3/4"	0.59
SBT34LHX1.102	3/4-16	1.102"	0.551"	5"	8 1/8"	0.97



LIFELINE HARDWARE

- 51** Lifeline Adjusters
- 52** Lifeline Studs
- 54** Lifeline Toggle Jaws
- 55** Lifeline Deck Toggle Jaws
- 56** Lifeline Toggle Jaw To Swage - Closed Body
- 57** Lifeline Toggle Jaw To Swage - Open Body
- 58** Lifeline Gate Eye To Swage - Closed Body
- 59** Lifeline Gate Eye To Swage - Open Body
- 60** Lifeline Deck Toggle To Swage - Closed Body
- 61** Lifeline Deck Toggle To Swage - Open Body
- 62** Lifeline Toggle Jaw To Gate Eye / Threaded Gate Eye Rods
- 63** Lifeline Single Gate Eyes / Interlocking Gate Eyes (Swivel Type)
- 64** Lifeline Single Gate Eyes / Interlocking Gate Eyes (Threaded Type)
- 65** Lifeline Gate Eyes / Pelican Hook Bodies
- 66** Positive Locking Pelican Hooks
- 67** Lifeline Termination Studs



LIFELINE ADJUSTERS - LONG

316 Stainless Steel

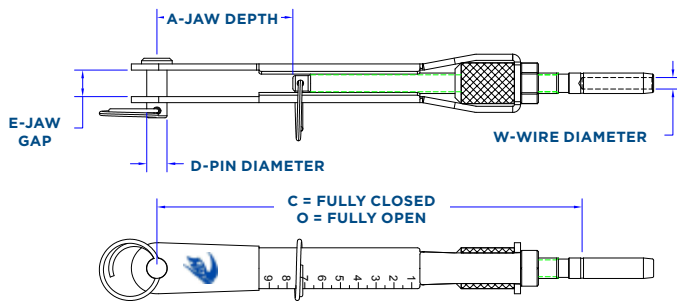

Imperial Wire Sizes - Machine Swage

Part #	W-Wire Ø	D-Pin Ø	Thread	O-Open L	C-Closed L	A-Jaw Depth	E-Jaw Gap	Weight lbs.
14SALL18	1/8"	1/4"	1/4-28 RH	7 3/8"	5 1/4"	1 5/16" min.	5/16"	0.18
14SALL532	5/32"	1/4"	1/4-28 RH	7 3/8"	5 1/4"	1 5/16" min.	5/16"	0.19
14SALL316	3/16"	1/4"	1/4-28 RH	7 3/8"	5 1/4"	1 5/16" min.	5/16"	0.20

Metric Wire Sizes - Machine Swage

14SALLM03	3mm	1/4"	1/4-28 RH	7 3/8"	5 1/4"	1 5/16" min.	5/16"	0.18
14SALLM04	4mm	1/4"	1/4-28 RH	7 3/8"	5 1/4"	1 5/16" min.	5/16"	0.19
14SALLM05	5mm	1/4"	1/4-28 RH	7 3/8"	5 1/4"	1 5/16" min.	5/16"	0.20

With Handy Crimp Stud

14SACLL18	1/8"	1/4"	1/4-28 RH	7 3/8"	5 1/4"	1 5/16" min.	5/16"	0.18
14SACLL316	3/16"	1/4"	1/4-28 RH	7 3/8"	5 1/4"	1 5/16" min.	5/16"	0.20

LIFELINE ADJUSTERS - SHORT

316 Stainless Steel

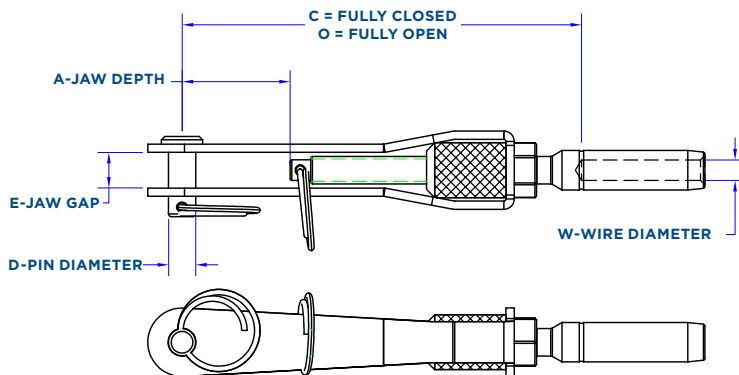

Imperial Wire Sizes - Machine Swage

Part #	W-Wire Ø	D-Pin Ø	Thread	O-Open L	C-Closed L	A-Jaw Depth	E-Jaw Gap	Weight lbs.
14ALL18	1/8"	1/4"	1/4-28 RH	4 1/2"	3 1/2"	1" min.	5/16"	0.15
14ALL532	5/32"	1/4"	1/4-28 RH	4 5/8"	3 5/8"	1" min.	5/16"	0.15
14ALL316	3/16"	1/4"	1/4-28 RH	4 1/4"	3 5/8"	1" min.	5/16"	0.16
14ALL14	1/4"	1/4"	5/16-24 RH	4 7/8"	3 7/8"	1" min.	5/16"	0.24

Metric Wire Sizes - Machine Swage

14ALLM04	4mm	1/4"	1/4-28 LH	4 5/8"	3 5/8"	1" min.	5/16"	0.15
14ALLM05	5mm	1/4"	1/4-28 LH	4 5/8"	3 5/8"	1" min.	5/16"	0.16

With Handy Crimp Stud

14ACLL18	1/8"	1/4"	1/4-28 RH	4 3/4"	3 3/4"	1" min.	5/16"	0.15
14ACLL316	3/16"	1/4"	1/4-28 RH	4 5/8"	3 5/8"	1" min.	5/16"	0.16

LIFELINE STUDS

316 Stainless Steel

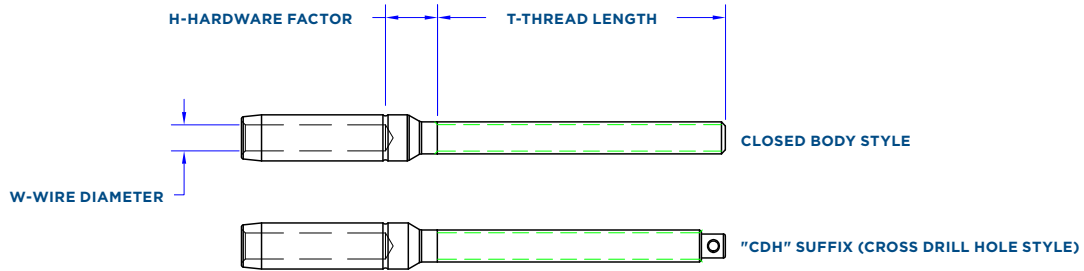

Imperial Wire Lifeline Studs - Machine Swage

Right Hand Thread Part #	Left Hand Thread Part #	W-Wire Ø	Thread Size	T-Thread Length	H-Hardware Factor	Where Used	Weight lbs.
10LL18RH	10LL18LH	1/8"	10-32	1 3/4"	3/8"	TB-Clsd	0.01
14LLE18RH	14LLE18LH	1/8"	1/4-28	7/16"	5/16"	Gate Eye	0.01
14LLP18RH	14LLP18LH	1/8"	1/4-28	1 1/2"	5/16"	P-Hook3	0.02
14LL18RH	14LL18LH	1/8"	1/4-28	2 1/4"	1/4"	TB-Clsd	0.03
14LL18RHCDH	14LL18LHCDH	1/8"	1/4-28	2 1/4"	1/4"	TB-Open	0.03
14ASLL18RH	-	1/8"	1/4-28	3 1/4"	5/16"	Adjuster	0.04
14LLE532RH	14LLE532LH	5/32"	1/4-28	7/16"	3/8"	Gate Eye	0.02
14LLP532RH	14LLP532LH	5/32"	1/4-28	1 1/2"	3/8"	P-Hook3	0.03
14LL532RH	14LL532LH	5/32"	1/4-28	2 1/4"	3/8"	TB-Clsd	0.04
14LL532RHCDH	14LL532LHCDH	5/32"	1/4-28	2 1/4"	3/8"	TB-Open	0.04
14ASLL532RH	-	5/32"	1/4-28	3 1/4"	7/16"	Adjuster	0.05
14LLE316RH	14LLE316LH	3/16"	1/4-28	7/16"	7/16"	Gate Eye	0.03
14LLP316RH	14LLP316LH	3/16"	1/4-28	1 1/2"	7/16"	P-Hook3	0.04
14LL316RH	14LL316LH	3/16"	1/4-28	2 1/4"	7/16"	TB-Clsd	0.05
14LL316RHCDH	14LL316LHCDH	3/16"	1/4-28	2 1/4"	7/16"	TB-Open	0.05
14ASLL316RH	-	3/16"	1/4-28	3 1/4"	7/16"	Adjuster	0.06
516LL18RH	-	1/8"	5/16-24	2 3/8"	9/16"	P-Hook4	0.04
516LLE532RH	516LLE532LH	5/32"	5/16-24	7/16"	9/16"	Gate Eye	0.03
516LLP532RH	516LLP532LH	5/32"	5/16-24	1 1/2"	9/16"	-	0.04
516LL532RH	516LL532LH	5/32"	5/16-24	2 3/8"	9/16"	TB-Clsd	0.06
516LL532RHCDH	516LL532LHCDH	5/32"	5/16-24	2 3/8"	9/16"	TB-Open	0.06
516LLE316RH	516LLE316LH	3/16"	5/16-24	7/16"	1/2"	Gate Eye	0.04
516LLP316RH	516LLP316LH	3/16"	5/16-24	1 1/2"	7/16"	-	0.06
516LL316RH	516LL316LH	3/16"	5/16-24	2 3/8"	7/16"	TB-Clsd	0.07
516LL316RHCDH	516LL316LHCDH	3/16"	5/16-24	2 3/8"	7/16"	TB-Open	0.07
516LLE14RH	516LLE14LH	1/4"	5/16-24	7/16"	11/16"	Gate Eye	0.06
516LLP14RH	516LLP14LH	1/4"	5/16-24	1 1/2"	3/8"	-	0.07
516LL14RH	516LL14LH	1/4"	5/16-24	2 3/8"	3/8"	TB-Clsd	0.09
516LL14RHCDH	516LL14LHCDH	1/4"	5/16-24	2 3/8"	3/8"	TB-Open	0.09
38LLE14RH	38LLE14LH	1/4"	3/8-24	7/16"	11/16"	Gate Eye	0.06
38LLP14RH	38LLP14LH	1/4"	3/8-24	1 1/2"	3/8"	-	0.08
38LL14RH	38LL14LH	1/4"	3/8-24	2 3/4"	7/16"	TB-Clsd	0.12
38LL14RHCDH	38LL14LHCDH	1/4"	3/8-24	2 3/4"	7/16"	TB-Open	0.12

Metric Thread Lifeline Studs - Machine Swage

6MLL18RH	6MLL18LH	1/8"	6mm	2 1/4"	1/4"	-	0.03
6MLL532RH	6MLL532LH	5/32"	6mm	2 1/4"	3/8"	-	0.04
6MLL316RH	6MLL316LH	3/16"	6mm	2 1/4"	7/16"	-	0.05
8MLL532RH	8MLL532LH	5/32"	8mm	2 3/8"	9/16"	-	0.06
8MLL316RH	8MLL316LH	3/16"	8mm	2 3/8"	1/2"	-	0.07
8MLL14RH	8MLL14LH	1/4"	8mm	2 3/8"	7/16"	-	0.09

*NOTE: 1/4" and 6mm lifeline fittings use 7/32" (5.5mm) swager dies and specifications.

LIFELINE STUDS (CONTINUED)

316 Stainless Steel

Metric Wire Lifeline Studs - Machine Swage

Right Hand Thread	Left Hand Thread						
Part #	Part #	W-Wire Ø	Thread Size	T-Thread Length	H-Hardware Factor	Where Used	Weight lbs.
14LLEM03RH	14LLEM03LH	3mm	1/4-28	7/16"	5/16"	Gate Eye	0.01
14LLPM03RH	14LLPM03LH	3mm	1/4-28	1 1/2"	5/16"	P-Hook3	0.02
14LLM03RH	14LLM03LH	3mm	1/4-28	2 1/4"	1/4"	TB-Clsd	0.03
14LLM03RHCDH	14LLM03LHCDH	3mm	1/4-28	2 1/4"	1/4"	TB-Open	0.03
14ASLLM03RH	-	3mm	1/4-28	3 1/4"	5/16"	Adjuster	0.04
14LLE5M04RH	14LLEM04LH	4mm	1/4-28	7/16"	3/8"	Gate Eye	0.02
14LLPM04RH	14LLPM04LH	4mm	1/4-28	1 1/2"	3/8"	P-Hook3	0.03
14LLM04RH	14LLM04LH	4mm	1/4-28	2 1/4"	3/8"	TB-Clsd	0.04
14LLM04RHCDH	14LLM04LHCDH	4mm	1/4-28	2 1/4"	3/8"	TB-Open	0.04
14ASLLM04RH	-	4mm	1/4-28	3 1/4"	7/16"	Adjuster	0.05
14LLEM05RH	14LLEM05LH	5mm	1/4-28	7/16"	7/16"	Gate Eye	0.03
14LLPM05RH	14LLPM05LH	5mm	1/4-28	1 1/2"	7/16"	P-Hook3	0.04
14LLM05RH	14LLM05LH	5mm	1/4-28	2 1/4"	7/16"	TB-Clsd	0.05
14LLM05RHCDH	14LLM05LHCDH	5mm	1/4-28	2 1/4"	7/16"	TB-Open	0.05
14ASLLM05RH	-	5mm	1/4-28	3 1/4"	7/16"	Adjuster	0.06
516LLEM04RH	516LLEM04LH	4mm	5/16-24	7/16"	9/16"	Gate Eye	0.03
516LLPM04RH	516LLPM04LH	4mm	5/16-24	1 1/2"	9/16"	-	0.04
516LLM04RH	516LLM04LH	4mm	5/16-24	2 3/8"	9/16"	TB-Clsd	0.06
516LLM04RHCDH	516LLM04LHCDH	4mm	5/16-24	2 3/8"	9/16"	TB-Open	0.06
516LLEM05RH	516LLEM05LH	5mm	5/16-24	7/16"	1/2"	Gate Eye	0.04
516LLPM05RH	516LLPM05LH	5mm	5/16-24	1 1/2"	7/16"	-	0.06
516LLM05RH	516LLM05LH	5mm	5/16-24	2 3/8"	7/16"	TB-Clsd	0.07
516LLM05RHCDH	516LLM05LHCDH	5mm	5/16-24	2 3/8"	7/16"	TB-Open	0.07
516LLEM06RH	516LLEM06LH	6mm	5/16-24	7/16"	11/16"	Gate Eye	0.06
516LLPM06RH	516LLPM06LH	6mm	5/16-24	1 1/2"	3/8"	-	0.07
516LLM06RH	516LLM06LH	6mm	5/16-24	2 3/8"	3/8"	TB-Clsd	0.09
516LLM06RHCDH	516LLM06LHCDH	6mm	5/16-24	2 3/8"	3/8"	TB-Open	0.09
38LLEM06RH	38LLEM06LH	6mm	3/8-24	7/16"	11/16"	Gate Eye	0.06
38LLPM06RH	38LLPM06LH	6mm	3/8-24	1 1/2"	3/8"	-	0.08
38LLM06RH	38LLM06LH	6mm	3/8-24	2 3/4"	7/16"	TB-Clsd	0.12
38LLM06RHCDH	38LLM06LHCDH	6mm	3/8-24	2 3/4"	7/16"	TB-Open	0.12

Imperial Wire Lifeline Studs - Handy Crimp (See Page 85 for crimp instructions.)

Right Hand Thread	Left Hand Thread						
Part #	Part #	W-Wire Ø	Thread Size	T-Thread Length	H-Hardware Factor	Where Used	Weight lbs.
14CLLE18RH	14CLLE18LH	1/8"	1/4-28	7/16"	9/16"	Gate Eye	0.01
14CLLP18RH	14CLLP18LH	1/8"	1/4-28	1 1/2"	9/16"	P-Hook3	0.02
14CLL18RH	14CLL18LH	1/8"	1/4-28	2 1/4"	5/8"	TB-Clsd	0.03
14CLL18RHCDH	14CLL18LHCDH	1/8"	1/4-28	2 1/4"	5/8"	TB-Open	0.03
14CLLE316RH	14CLLE316LH	3/16"	1/4-28	7/16"	11/16"	-	0.03
14CLLP316RH	14CLLP316LH	3/16"	1/4-28	1 1/2"	3/8"	P-Hook3	0.04
14CLL316RH	14CLL316LH	3/16"	1/4-28	2 1/4"	9/16"	TB-Clsd	0.05
14CLL316RHCDH	14CLL316LHCDH	3/16"	1/4-28	2 1/4"	9/16"	TB-Open	0.05
14CASLL316RH	-	3/16"	1/4-28	3 1/4"	3/8"	Adjuster	0.06
516CLL18RH	-	1/8"	5/16-24	2 3/8"	9/16"	P-Hook4	0.06
516CLLE316RH	516CLLE316LH	3/16"	5/16-24	7/16"	7/16"	Gate Eye	0.04
516CLLP316RH	516CLLP316LH	3/16"	5/16-24	1 1/2"	1/2"	-	0.06
516CLL316RH	516CLL316LH	3/16"	5/16-24	2 3/8"	1/2"	TB-Clsd	0.07
516CLL316RHCDH	516CLL316LHCDH	3/16"	5/16-24	2 3/8"	1/2"	TB-Open	0.07

LIFELINE TOGGLE JAWS

316 Stainless Steel

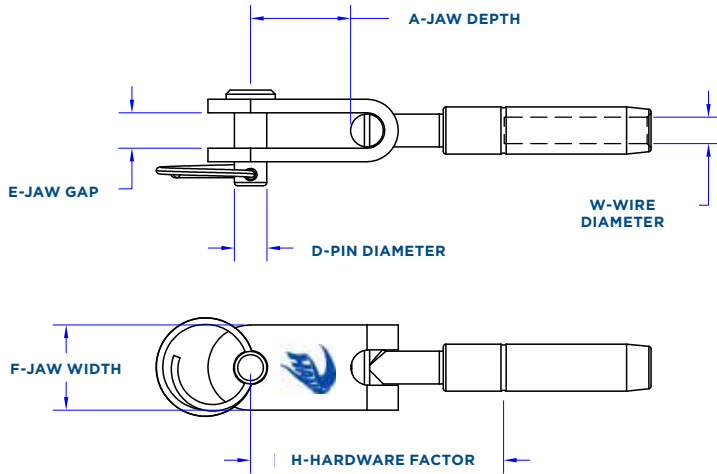

SMART PART # KEY toggle pin size | [Toggle Jaw Life Line](#) | wire size

Imperial Wire Sizes - Machine Swage

Part #	W-Wire Ø	D-Pin Ø	A-Jaw Depth	E-Jaw Gap	F-Jaw Width	H-Hardware Factor	Weight lbs.
14TJLL18	1/8"	1/4"	3/4"	1/4"	21/32"	2 7/16"	0.10
14TJLL532	5/32"	1/4"	3/4"	1/4"	21/32"	2 7/32"	0.10
14TJLL316	3/16"	1/4"	3/4"	1/4"	21/32"	1 15/16"	0.10
516TJLL316	3/16"	5/16"	13/16"	5/16"	3/4"	2 9/16"	0.16
516TJLL14	1/4"	5/16"	13/16"	5/16"	3/4"	2 3/8"	0.17
38TJLL14	1/4"	3/8"	1"	3/8"	7/8"	2 5/8"	0.24

Metric Wire Sizes - Machine Swage

14TJLLM04	4mm	1/4"	3/4"	1/4"	21/32"	2 7/32"	0.10
14TJLLM05	5mm	1/4"	3/4"	1/4"	21/32"	1 15/16"	0.10

With Handy Crimp Stud

14TJCLL18	1/8"	1/4"	3/4"	1/4"	21/32"	2 1/2"	0.10
14TJCLL316	3/16"	1/4"	3/4"	1/4"	21/32"	2 5/32"	0.10
516TJCLL316	3/16"	5/16"	13/16"	5/16"	3/4"	2 11/16"	0.15

***NOTE:** 1/4" and 6mm lifeline fittings use 7/32" (5.5mm) swager dies and specifications.



LIFELINE DECK TOGGLE JAWS

316 Stainless Steel

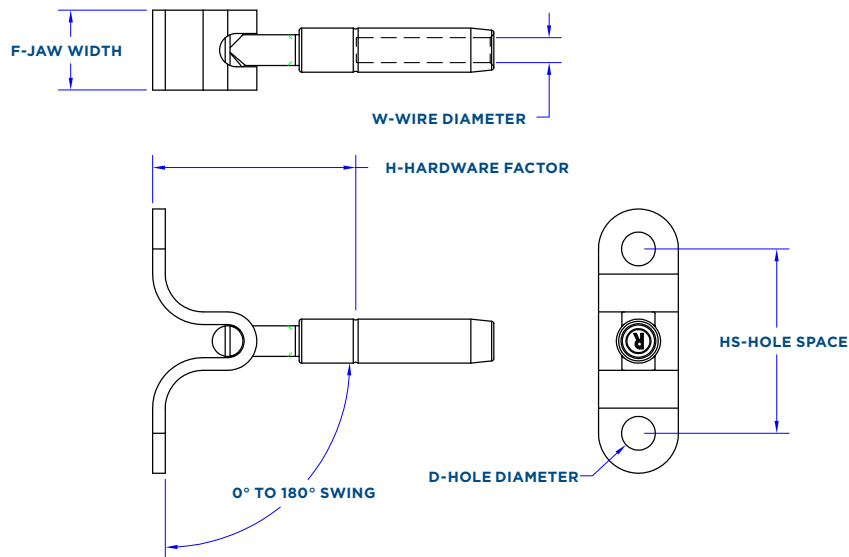

SMART PART # KEY toggle pin size | [Toggle Jaw Life Line](#) | wire size | [Deck Toggle](#)

Imperial Wire Sizes - Machine Swage

Part #	W-Wire Ø	D-Hole Ø	HS-Hole Space	F-Jaw Width	H-Hardware Factor	Weight lbs.
14TJLL18DT	1/8"	1/4"	1 1/2"	21/32"	2 1/4"	0.08
14TJLL532DT	5/32"	1/4"	1 1/2"	21/32"	1 15/16"	0.09
14TJLL316DT	3/16"	1/4"	1 1/2"	21/32"	1 5/8"	0.09
516TJLL14DT	1/4"	5/16"	1 3/4"	3/4"	2"	0.16
38TJLL14DT	1/4"	3/8"	2"	57/64"	2 1/4"	0.22

Metric Wire Sizes - Machine Swage

14TJLLM04DT	4mm	1/4"	1 1/2"	21/32"	1 15/16"	0.09
14TJLLM05DT	5mm	1/4"	1 1/2"	21/32"	1 5/8"	0.09

With Handy Crimp Stud

14TJCLL18DT	1/8"	1/4"	1 1/2"	21/32"	2 1/4"	0.08
14TJCLL316DT	3/16"	1/4"	1 1/2"	21/32"	1 7/8"	0.09

***NOTE:** 1/4" and 6mm lifeline fittings use 7/32" (5.5mm) swager dies and specifications.

LIFELINE TOGGLE JAW TO SWAGE - CLOSED BODY

316 Stainless Steel

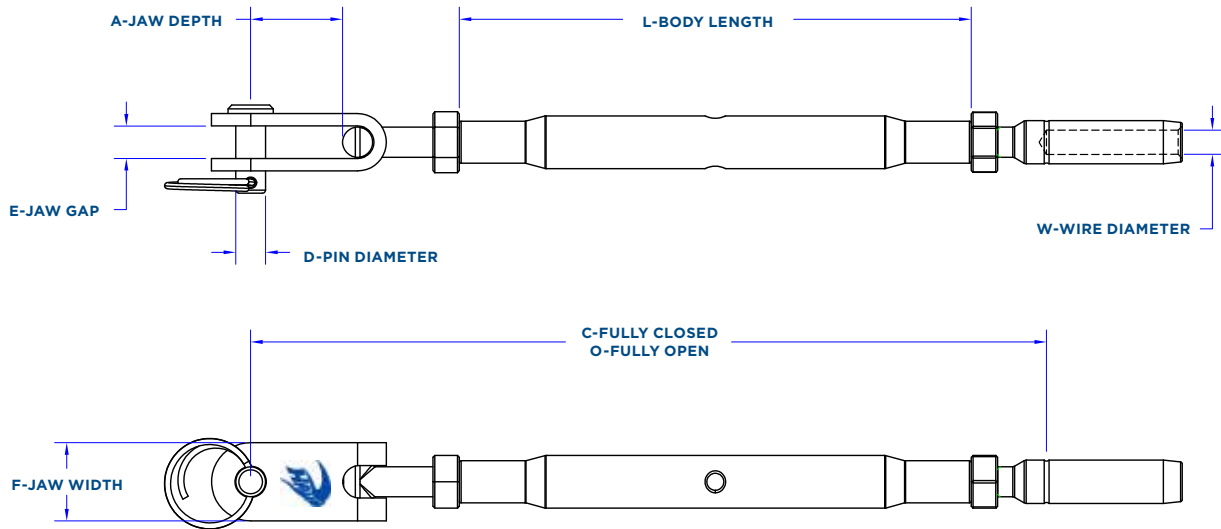

SMART PART # KEY toggle pin size | [Tubular Turnbuckle](#) [Life Line](#) | wire size

Imperial Wire Sizes - Machine Swage

Part #	W-Wire Ø	Thread	D-Pin Ø	O-Open L	C-Closed L	L-Body	A-Jaw Depth	E-Jaw Gap	F-Jaw Width	Weight lbs.
14TTLL18	1/8"	1/4-28	1/4"	9 1/2"	6 1/2"	4 1/4"	3/4"	1/4"	21/32"	0.22
14TTLL532	5/32"	1/4-28	1/4"	9 9/16"	6 9/16"	4 1/4"	3/4"	1/4"	21/32"	0.23
14TTLL316	3/16"	1/4-28	1/4"	9 5/8"	6 5/8"	4 1/4"	3/4"	1/4"	21/32"	0.24
516TTLL316	3/16"	5/16-24	5/16"	10 11/16"	7 7/16"	5"	13/16"	5/16"	3/4"	0.39
516TTLL14	1/4"	5/16-24	5/16"	10 3/4"	7 1/2"	5"	13/16"	5/16"	3/4"	0.42
38TTLL14	1/4"	3/8-24	3/8"	1'-0 1/8"	8 3/8"	5 1/2"	1"	3/8"	57/64"	0.57

Metric Wire Sizes - Machine Swage

14TTLLM04	4mm	1/4-28	1/4"	9 9/16"	6 9/16"	4 1/4"	3/4"	1/4"	21/32"	0.23
14TTLLM05	5mm	1/4-28	1/4"	9 5/8"	6 5/8"	4 1/4"	3/4"	1/4"	21/32"	0.24

With Handy Crimp Stud

14TTCLL18	1/8"	1/4-28	1/4"	9 11/16"	6 11/16"	4 1/4"	3/4"	1/4"	21/32"	0.22
14TTCLL316	3/16"	1/4-28	1/4"	9 9/16"	6 9/16"	4 1/4"	3/4"	1/4"	21/32"	0.23
516TTCLL316	3/16"	5/16-24	5/16"	10 13/16"	7 9/16"	5"	13/16"	5/16"	3/4"	0.38

*NOTE: 1/4" and 6mm lifeline fittings use 7/32" (5.5mm) swager dies and specifications.

LIFELINE TOGGLE JAW TO SWAGE - OPEN BODY

316 Stainless Steel / Chromed Bronze Turnbuckle Body

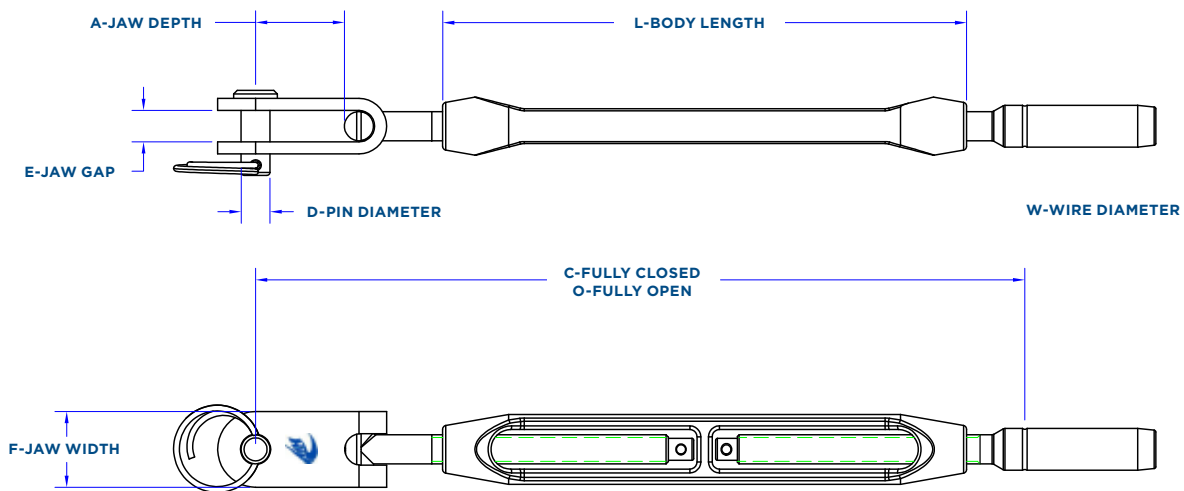

SMART PART # KEY toggle pin size | Turnbuckle Forged Bronze Life Line | wire size

Imperial Wire Sizes - Machine Swage

Part #	W-Wire Ø	Thread	D-Pin Ø	O-Open L	C-Closed L	L-Body	A-Jaw Depth	E-Jaw Gap	F-Jaw Width	Weight lbs.
14TFBLL18	1/8"	1/4-28	1/4"	9 1/2"	6 1/2"	4 1/2"	3/4"	1/4"	21/32"	0.23
14TFBLL532	5/32"	1/4-28	1/4"	9 9/16"	6 9/16"	4 1/2"	3/4"	1/4"	21/32"	0.24
14TFBLL316	3/16"	1/4-28	1/4"	9 5/8"	6 5/8"	4 1/2"	3/4"	1/4"	21/32"	0.25
516TFBLL316	3/16"	5/16-24	5/16"	10 5/16"	7 1/16"	5"	13/16"	5/16"	3/4"	0.41
516TFBLL14	1/4"	5/16-24	5/16"	10 3/8"	7 1/8"	5"	13/16"	5/16"	3/4"	0.44
38TFBLL14	1/4"	3/8-24	3/8"	11 3/8"	7 7/8"	5 1/2"	1"	3/8"	7/8"	0.61

Metric Wire Sizes - Machine Swage

14TFBLLM04	4mm	1/4-28	1/4"	9 9/16"	6 9/16"	4 1/2"	3/4"	1/4"	21/32"	0.24
14TFBLLM05	5mm	1/4-28	1/4"	9 5/8"	6 5/8"	4 1/2"	3/4"	1/4"	21/32"	0.25
516TFBLLM05	5mm	5/16-24	5/16"	10 5/16"	7 1/16"	5"	13/16"	5/16"	3/4"	0.41

With Handy Crimp Stud

14TFBCLL18	1/8"	1/4-28	1/4"	9 7/8"	6 7/8"	4 1/2"	3/4"	1/4"	21/32"	0.24
14TFBCLL316	3/16"	1/4-28	1/4"	9 9/16"	6 9/16"	4 1/2"	3/4"	1/4"	21/32"	0.25
516TFBCLL316	3/16"	5/16-24	5/16"	10 7/16"	7 3/16"	5"	13/16"	5/16"	3/4"	0.40

*NOTE: 1/4" and 6mm lifeline fittings use 7/32" (5.5mm) swager dies and specifications.

LIFELINE GATE EYE TO SWAGE - CLOSED BODY

316 Stainless Steel

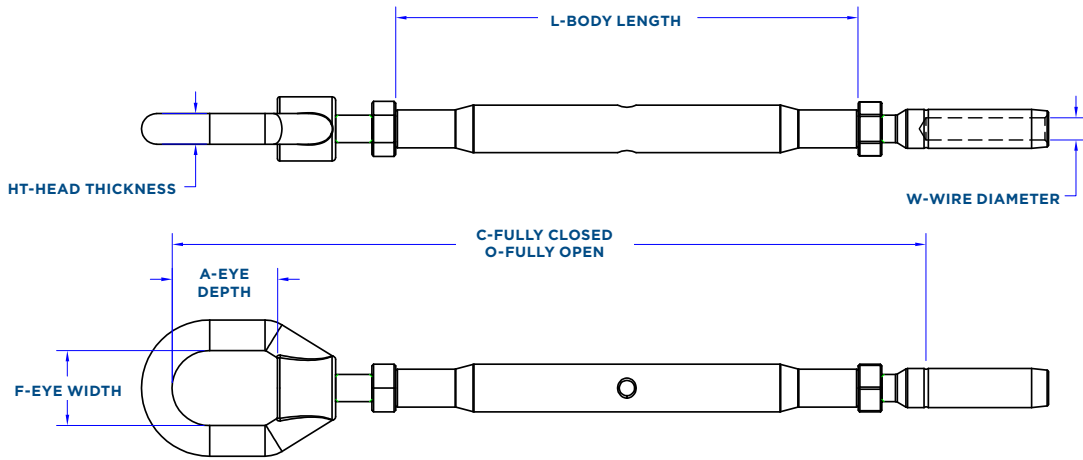

SMART PART # KEY toggle pin size | [Tubular Turnbuckle Life Line](#) | wire size | [gate Eye](#)

Imperial Wire Sizes - Machine Swage

Part #	W-Wire Ø	Thread	O-Open L	C-Closed L	L-Body	A-Eye Depth	F-Eye Width	HT-Head Thickness	Weight lbs.
14TTLL18E	1/8"	1/4-28	9 13/16"	6 13/16"	4 1/4"	31/32"	11/16"	9/32"	0.22
14TTLL532E	5/32"	1/4-28	9 7/8"	6 7/8"	4 1/4"	31/32"	11/16"	9/32"	0.23
14TTLL316E	3/16"	1/4-28	9 15/16"	6 15/16"	4 1/4"	31/32"	11/16"	9/32"	0.24
516TTLL316E	3/16"	5/16-24	11 3/16"	7 15/16"	5"	31/32"	11/16"	9/32"	0.37
516TTLL14E	1/4"	5/16-24	11 1/4"	8"	5"	31/32"	11/16"	9/32"	0.40
38TTLL14E	1/4"	3/8-24	1'-0 3/8"	8 5/8"	5 1/2"	31/32"	11/16"	9/32"	0.52

Metric Wire Sizes - Machine Swage

14TTLLM04E	4mm	1/4-28	9 7/8"	6 7/8"	4 1/4"	31/32"	11/16"	9/32"	0.23
14TTLLM05E	5mm	1/4-28	9 15/16"	6 15/16"	4 1/4"	31/32"	11/16"	9/32"	0.24

With Handy Crimp Stud

14TTCLL18E	1/8"	1/4-28	10"	7"	4 1/4"	31/32"	11/16"	9/32"	0.23
14TTCLL316E	3/16"	1/4-28	9 7/8"	6 7/8"	4 1/4"	31/32"	11/16"	9/32"	0.24
516TTCLL316E	3/16"	5/16-24	11 5/16"	8 1/16"	5"	31/32"	11/16"	9/32"	0.36

*NOTE: 1/4" and 6mm lifeline fittings use 7/32" (5.5mm) swager dies and specifications.

LIFELINE GATE EYE TO SWAGE - OPEN BODY

316 Stainless Steel

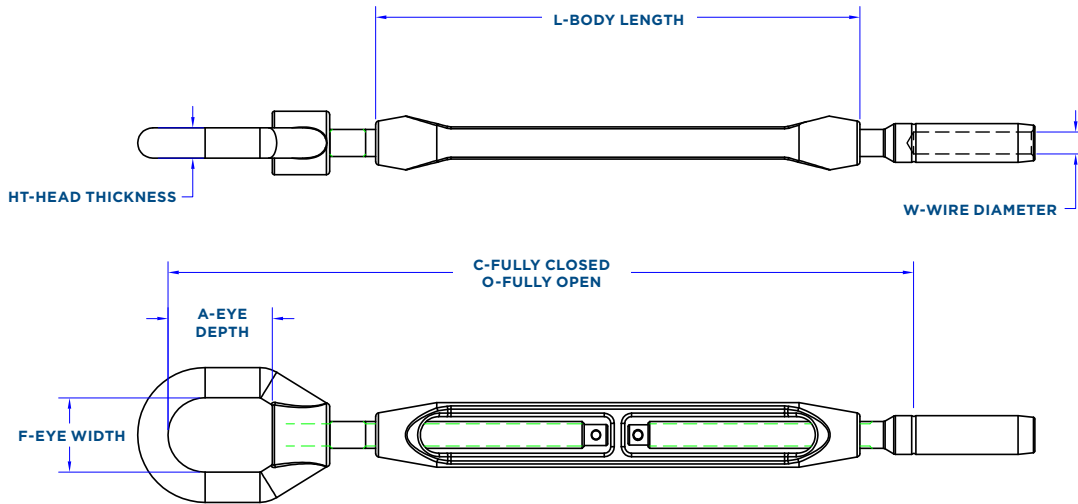

SMART PART # KEY toggle pin size | Turnbuckle Forged Bronze Life Line | wire size | gate Eye

Imperial Wire Sizes - Machine Swage

Part #	W-Wire Ø	Thread	O-Open L	C-Closed L	L-Body	A-Eye Depth	F-Eye Width	HT-Head Thickness	Weight lbs.
14TFBLL18E	1/8"	1/4-28	9 13/16"	6 13/16"	4 1/2"	31/32"	11/16"	9/32"	0.24
14TFBLL532E	5/32"	1/4-28	9 7/8"	6 7/8"	4 1/2"	31/32"	11/16"	9/32"	0.25
14TFBLL316E	3/16"	1/4-28	9 15/16"	6 15/16"	4 1/2"	31/32"	11/16"	9/32"	0.26
516TFBLL316E	3/16"	5/16-24	10 13/16"	7 9/16"	5"	31/32"	11/16"	9/32"	0.39
516TFBLL14E	1/4"	5/16-24	10 7/8"	7 5/8"	5"	31/32"	11/16"	9/32"	0.42
38TFBLL14E	1/4"	3/8-24	11 11/16"	8 3/16"	5 1/2"	31/32"	11/16"	9/32"	0.56

Metric Wire Sizes - Machine Swage

14TFBLLM04E	4mm	1/4-28	9 7/8"	6 7/8"	4 1/2"	31/32"	11/16"	9/32"	0.25
14TFBLLM05E	5mm	1/4-28	9 15/16"	6 15/16"	4 1/2"	31/32"	11/16"	9/32"	0.26
516TFBLLM05E	5mm	5/16-24	10 13/16"	7 9/16"	5"	31/32"	11/16"	9/32"	0.39

With Handy Crimp Stud

14TFBCLL18E	1/8"	1/4-28	10"	7"	4 1/2"	31/32"	11/16"	9/32"	0.24
14TFBCLL316E	3/16"	1/4-28	9 7/8"	6 7/8"	4 1/2"	31/32"	11/16"	9/32"	0.25
516TFBCLL316E	3/16"	5/16-24	10 15/16"	7 11/16"	5"	31/32"	11/16"	9/32"	0.38

*NOTE: 1/4" and 6mm lifeline fittings use 7/32" (5.5mm) swager dies and specifications.

LIFELINE DECK TOGGLE TO SWAGE - CLOSED BODY

316 Stainless Steel

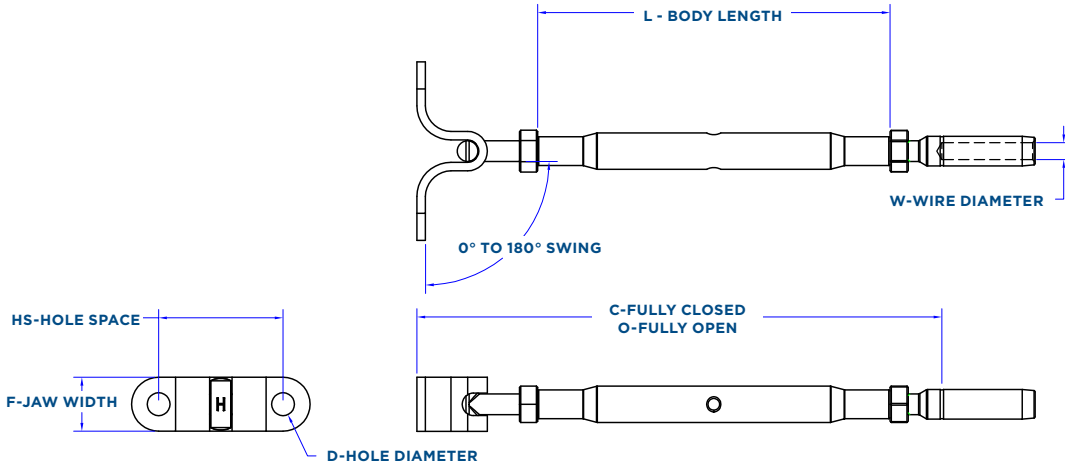

SMART PART # KEY toggle pin size | Tubular Turnbuckle Life Line | wire size | Deck Toggle

Imperial Wire Sizes - Machine Swage

Part #	W-Wire Ø	Thread Size	D-Hole Ø	HS-Hole Space	O-Open L	C-Closed L	L-Body	F-Jaw Width	Weight lbs.
14TTLL18DT	1/8"	1/4-28	1/4"	1 1/2"	9 7/32"	6 7/32"	4 1/4"	21/32"	0.18
14TTLL532DT	5/32"	1/4-28	1/4"	1 1/2"	9 3/8"	6 3/8"	4 1/4"	21/32"	0.22
14TTLL316DT	3/16"	1/4-28	1/4"	1 1/2"	9 3/8"	6 3/8"	4 1/4"	21/32"	0.22
516TTLL316DT	3/16"	5/16-24	5/16"	1 3/4"	10 1/4"	7"	5"	3/4"	0.33
516TTLL14DT	1/4"	5/16-24	5/16"	1 3/4"	10 3/8"	7 1/8"	5"	3/4"	0.40
38TTLL14DT	1/4"	3/8-24	3/8"	2"	11 11/16"	7 15/16"	5 1/2"	57/64"	0.54

Metric Wire Sizes - Machine Swage

14TTLLM04DT	4mm	1/4-28	1/4"	1 1/2"	9 5/16"	6 5/16"	4 1/4"	21/32"	0.22
14TTLLM05DT	5mm	1/4-28	1/4"	1 1/2"	9 5/16"	6 5/16"	4 1/4"	21/32"	0.22

With Handy Crimp Stud

14TTCLL18DT	1/8"	1/4-28	1/4"	1 1/2"	9 7/16"	6 7/16"	4 1/4"	21/32"	0.21
14TTCLL316DT	3/16"	1/4-28	1/4"	1 1/2"	9 5/16"	6 5/16"	4 1/4"	21/32"	0.22
516TTCLL316DT	3/16"	5/16-24	5/16"	1 3/4"	10 7/16"	7 3/16"	5"	3/4"	0.36

*NOTE: 1/4" and 6mm lifeline fittings use 7/32" (5.5mm) swager dies and specifications.



LIFELINE DECK TOGGLE TO SWAGE - OPEN BODY

316 Stainless Steel

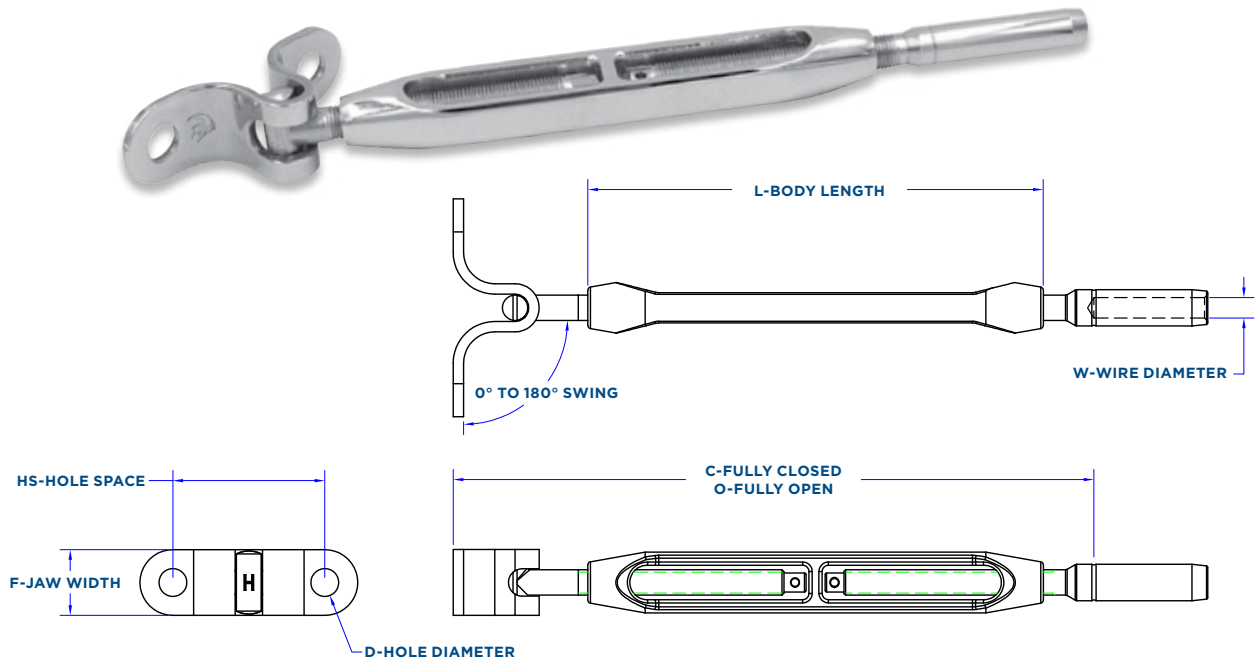

SMART PART # KEY toggle pin size | Turnbuckle Forged Bronze Life Line | wire size | Deck Toggle

Imperial Wire Sizes - Machine Swage

Part #	W-Wire Ø	Thread Size	D-Hole Ø	HS-Hole Space	O-Open L	C-Closed L	L-Body	F-Jaw Width	Weight lbs.
14TFBLL18DT	1/8"	1/4-28	1/4"	1 1/2"	9 3/16"	6 3/16"	4 1/2"	21/32"	0.22
14TFBLL532DT	5/32"	1/4-28	1/4"	1 1/2"	9 1/4"	6 1/4"	4 1/2"	21/32"	0.23
14TFBLL316DT	3/16"	1/4-28	1/4"	1 1/2"	9 3/8"	6 3/8"	4 1/2"	21/32"	0.24
516TFBLL316DT	3/16"	5/16-24	5/16"	1 3/4"	9 7/8"	6 5/8"	5"	3/4"	0.39
516TFBLL14DT	1/4"	5/16-24	5/16"	1 3/4"	10 3/16"	6 15/16"	5"	3/4"	0.42
38TFBLL14DT	1/4"	3/8-24	3/8"	2"	10 15/16"	7 7/16"	5 1/2"	57/64"	0.58

Metric Wire Sizes - Machine Swage

14TFBLLM04DT	4mm	1/4-28	1/4"	1 1/2"	9 5/16"	6 5/16"	4 1/2"	21/32"	0.23
14TFBLLM05DT	5mm	1/4-28	1/4"	1 1/2"	9 5/16"	6 5/16"	4 1/2"	21/32"	0.24

With Handy Crimp Stud

14TFBCLL18DT	1/8"	1/4-28	1/4"	1 1/2"	9 7/16"	6 7/16"	4 1/2"	21/32"	0.22
14TFBCLL316DT	3/16"	1/4-28	1/4"	1 1/2"	9 5/16"	6 5/16"	4 1/2"	21/32"	0.23
516TFBCLL316DT	3/16"	5/16-24	5/16"	1 3/4"	10 1/16"	6 13/16"	5"	3/4"	0.38

***NOTE: 1/4" and 6mm lifeline fittings use 7/32" (5.5mm) swager dies and specifications.**



LIFELINE TOGGLE JAW TO GATE EYE - CLOSED BODY

316 Stainless Steel

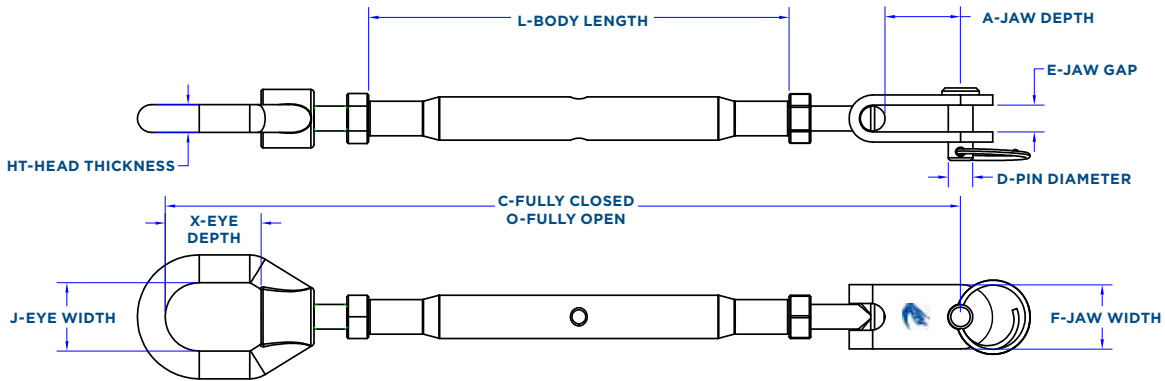

SMART PART # KEY toggle pin size | Tubular Turnbuckle Life Line Jaw Eye

Part #	Wire Sizes	Thread	D-Pin Ø	O-Open L	C-Closed L	L-Body	A-Jaw Depth	E-Jaw Gap	F-Jaw Width	X-Eye Depth	J-Eye Width	HT-Head Thickness	Weight lbs.
14TLLJE	3/32" - 5/32"	1/4-28	1/4"	11"	8"	4 1/4"	3/4"	1/4"	21/32"	31/32"	11/16"	9/32"	0.28
516TLLJE	5/32" - 3/16"	5/16-24	5/16"	1'-0 3/8"	9 1/8"	5"	13/16"	5/16"	3/4"	31/32"	11/16"	9/32"	0.45
38TLLJE	3/16" - 1/4"	3/8-24	3/8"	1'-1 3/4"	10"	5 1/2"	1"	3/8"	7/8"	31/32"	11/16"	9/32"	0.65

LIFELINE THREADED GATE EYE RODS (Left Hand Thread)

316 Stainless Steel

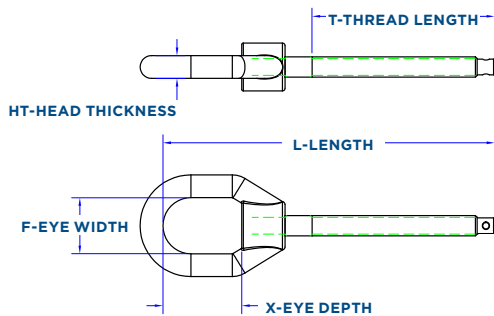

Part # Pin Hole	Part # W/O Pin Hole	Thread	HD-Head Ø	X-Eye Depth	F-Eye Width	HT-Head Thickness	T-Thread Length	Weight lbs.
14LLERLH	14LLERLH-P	1/4-28	19/32"	31/32"	11/16"	9/32"	2 1/4"	0.10
516LLERLH	516LLERLH-P	5/16-24	19/32"	31/32"	11/16"	9/32"	2 3/8"	0.12
38LLERLH	516LLERLH-P	3/8-24	19/32"	31/32"	11/16"	9/32"	2 3/4"	0.18

LIFELINE SINGLE GATE EYES (SWIVEL TYPE)

316 Stainless Steel

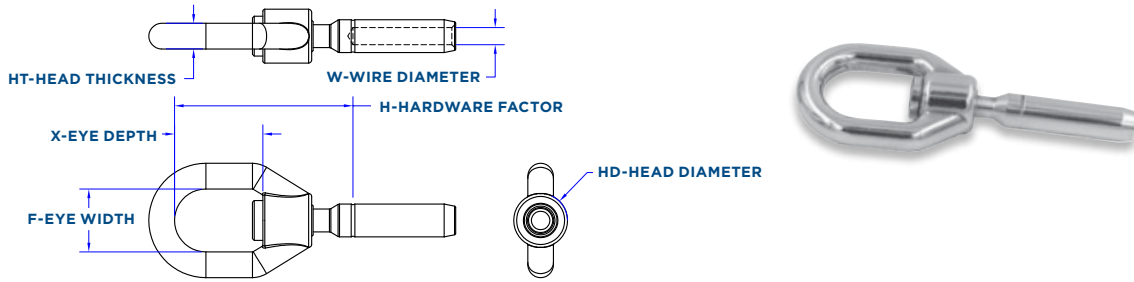

Imperial Wire Sizes - Machine Swage

Part #	W-Wire Ø	Thread	X-Eye Depth	F-Eye Width	HD-Head Diameter	HT-Thickness	H-Hardware Factor	Weight lbs.
SWELLS18	1/8"	1/4-28	31/32"	11/16"	19/32"	9/32"	1 13/16"	0.11
SWELLS532	5/32"	5/16-24	31/32"	11/16"	19/32"	9/32"	1 7/8"	0.13
SWELLS316	3/16"	5/16-24	31/32"	11/16"	19/32"	9/32"	1 15/16"	0.14
SWELLS14	1/4"	3/8-24	31/32"	11/16"	19/32"	9/32"	2 7/32"	0.16

Metric Wire Sizes - Machine Swage

SWELLSM04	4mm	5/16-24	31/32"	11/16"	19/32"	9/32"	1 7/8"	0.13
SWELLSM05	5mm	5/16-24	31/32"	11/16"	19/32"	9/32"	1 15/16"	0.14

With Handy Crimp Stud

SWECLLS18	1/8"	1/4-28	31/32"	11/16"	19/32"	9/32"	2"	0.11
SWECLLS316	3/16"	5/16-24	31/32"	11/16"	19/32"	9/32"	1 7/8"	0.13

LIFELINE INTERLOCKING GATE EYES (SWIVEL TYPE)

316 Stainless Steel

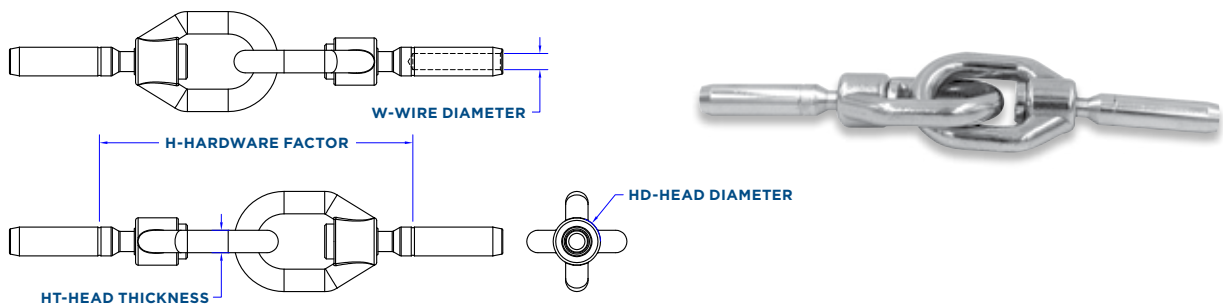

Imperial Wire Sizes - Machine Swage

Part #	W-Wire Ø	HD-Head Diameter	HT-Head Thickness	H-Hardware Factor	Weight lbs.
SWELLI18	1/8"	19/32"	9/32"	3 11/16"	0.23
SWELLI532	5/32"	19/32"	9/32"	3 13/16"	0.25
SWELLI316	3/16"	19/32"	9/32"	3 15/16"	0.27
SWELLI14	1/4"	19/32"	9/32"	4 7/16"	0.32

Metric Wire Sizes - Machine Swage

SWELLIM04	4mm	19/32"	9/32"	3 13/16"	0.25
SWELLIM05	5mm	19/32"	9/32"	3 15/16"	0.27

With Handy Crimp Stud

SWECLLI18	1/8"	19/32"	9/32"	4 1/16"	0.22
SWECLLI316	3/16"	19/32"	9/32"	3 13/16"	0.26

LIFELINE SINGLE GATE EYES (THREADED TYPE)

316 Stainless Steel

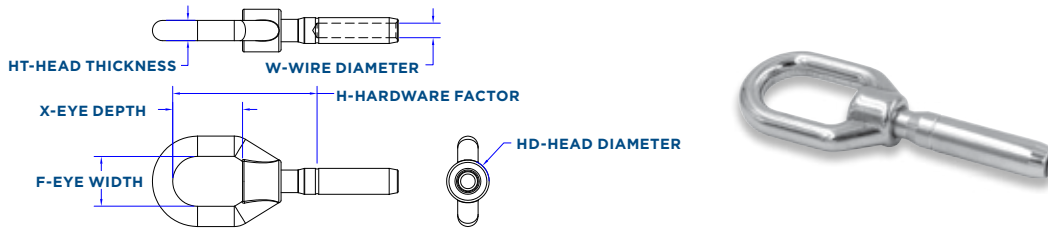

Imperial Wire Sizes - Machine Swage

Part #	W-Wire Ø	Thread	X-Eye Depth	F-Eye Width	HD-Head Diameter	HT-Thickness	H-Hardware Factor	Weight lbs.
14ELLS18	1/8"	1/4-28	31/32"	11/16"	19/32"	9/32"	1 13/16"	0.08
516ELLS532	5/32"	5/16-24	31/32"	11/16"	19/32"	9/32"	1 15/16"	0.09
516ELLS316	3/16"	5/16-24	31/32"	11/16"	19/32"	9/32"	2"	0.10
38ELLS14	1/4"	3/8-24	31/32"	11/16"	19/32"	9/32"	1 7/8"	0.15

Metric Wire Sizes - Machine Swage

516ELLSM04	4mm	5/16-24	31/32"	11/16"	19/32"	9/32"	1 15/16"	0.09
516ELLSM05	5mm	5/16-24	31/32"	11/16"	19/32"	9/32"	2"	0.10

With Handy Crimp Stud

14ECLS18	1/8"	1/4-28	31/32"	11/16"	19/32"	9/32"	2"	0.08
516ECLS316	3/16"	5/16-24	31/32"	11/16"	19/32"	9/32"	1 15/16"	0.09

LIFELINE INTERLOCKING GATE EYES (THREADED TYPE)

316 Stainless Steel

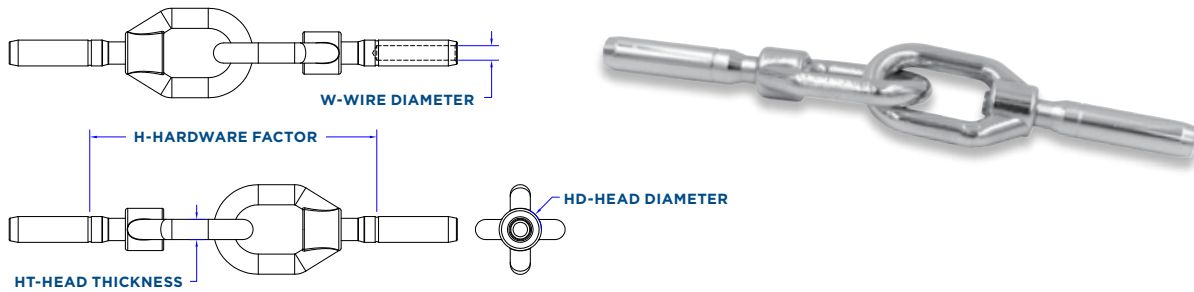

Imperial Wire Sizes - Machine Swage

Part #	W-Wire Ø	Thread	HD-Head Diameter	HT-Thickness	H-Hardware Factor	Weight lbs.
14ELLI18	1/8"	1/4-28	19/32"	9/32"	3 5/8"	0.16
516ELLI532	5/32"	5/16-24	19/32"	9/32"	3 15/16"	0.19
516ELLI316	3/16"	5/16-24	19/32"	9/32"	4"	0.21
38ELLI14	1/4"	3/8-24	19/32"	9/32"	3 3/4"	0.30

Metric Wire Sizes - Machine Swage

516ELLIM04	4mm	5/16-24	19/32"	9/32"	3 15/16"	0.19
516ELLIM05	5mm	5/16-24	19/32"	9/32"	4"	0.20

With Handy Crimp Stud

14ECLI18	1/8"	1/4-28	19/32"	9/32"	4"	0.17
516ECLI316	3/16"	5/16-24	19/32"	9/32"	3 7/8"	0.19

LIFELINE GATE EYES (THREADED TYPE WITHOUT STUDS)

316 Stainless Steel

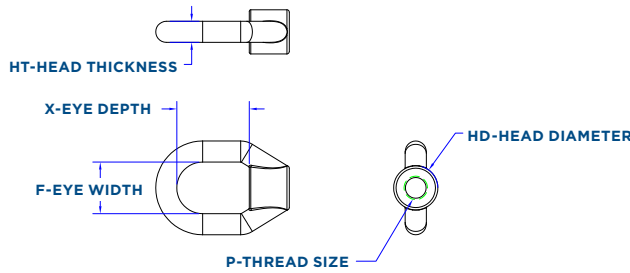

Single Eye

Part #	P-Thread	HD-Head Ø	X-Eye Depth	F-Eye Width	HT-Head Thickness	Weight lbs.
14ELLS	1/4-28 LH	9/16"	31/32"	11/16"	9/32"	0.06
516ELLS	5/16-24 LH	9/16"	31/32"	11/16"	9/32"	0.06
38ELLS	3/8-24 LH	9/16"	31/32"	11/16"	9/32"	0.08

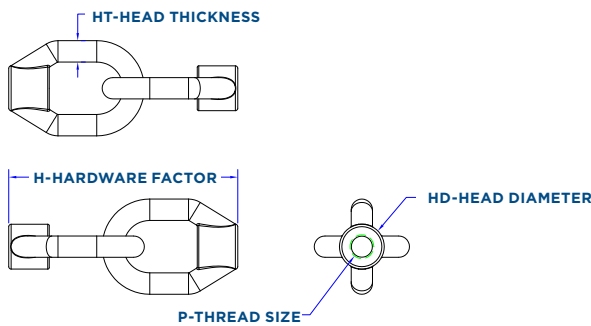

Interlocking Eyes

Part #	P-Thread	HD-Head Ø	HT-Head Thickness	H-Hardware Factor	Weight lbs.
14ELLI	1/4-28 LH	9/16"	9/32"	2 7/8"	0.06
516ELLI	5/16-24 LH	9/16"	9/32"	3"	0.06
38ELLI	3/8-24 LH	9/16"	9/32"	3"	0.08

LIFELINE PELICAN HOOK BODIES

316 Stainless Steel

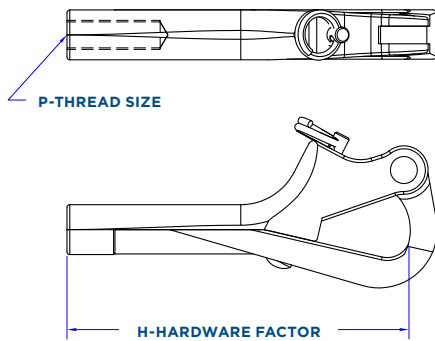

Right Hand

Left Hand

Part #	Part #	P-Thread Size	Body Size	H-Hardware Factor	Weight lbs.
FPHB3RH	-	1/4-28	3"	2 3/4"	0.15
FPHBRH	FPHBLH	5/16-24	4"	3 5/8"	0.30

4 INCH POSITIVE LOCKING PELICAN HOOKS

316 Stainless Steel

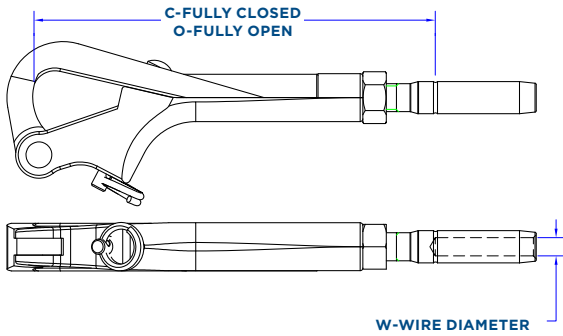

Imperial Wire Sizes - Machine Swage

Part #	W-Wire Ø	Thread	O-Open L	C-Closed L	Weight lbs.
FPHLL18	1/8"	5/16-24 RH	6"	4 1/2"	0.37
FPHLL532	5/32"	5/16-24 RH	6 1/8"	4 5/8"	0.37
FPHLL316	3/16"	5/16-24 RH	6"	4 1/2"	0.38
FPHLL14	1/4"	5/16-24 RH	6 1/8"	4 5/8"	0.40

Metric Wire Sizes - Machine Swage

FPHLLM04	4mm	5/16-24 RH	6 1/8"	4 5/8"	0.37
FPHLLM05	5mm	5/16-24 RH	6"	4 1/2"	0.38
FPHLLM06	6mm	5/16-24 RH	6"	4 5/8"	0.41

With Handy Crimp Stud

FPHCLL18	1/8"	5/16-24 RH	6 1/8"	4 5/8"	0.37
FPHCLL316	3/16"	5/16-24 RH	6 1/8"	4 5/8"	0.37

*NOTE: 1/4" and 6mm lifeline fittings use 7/32" (5.5mm) swager dies and specifications.

3 INCH POSITIVE LOCKING PELICAN HOOKS

316 Stainless Steel

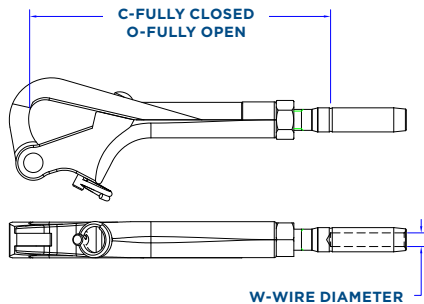

Imperial Wire Sizes - Machine Swage

Part #	W-Wire Ø	Thread	O-Open L	C-Closed L	Weight lbs.
FPHLL183	1/8"	1/4-28 RH	4"	3"	0.19
FPHLL5323	5/32"	1/4-28 RH	4 1/8"	3 1/8"	0.20
FPHLL3163	3/16"	1/4-28 RH	4 1/4"	3 1/4"	0.21

Metric Wire Sizes - Machine Swage

FPHLLM033	3mm	1/4-28 RH	4"	3"	0.19
FPHLLM043	4mm	1/4-28 RH	4 1/8"	3 1/8"	0.20
FPHLLM053	5mm	1/4-28 RH	4 1/4"	3 1/4"	0.21

With Handy Crimp Stud

FPHCLL183	1/8"	1/4-28 RH	4 1/4"	3 1/4"	0.20
FPHCLL3163	3/16"	1/4-28 RH	4 3/8"	3 3/8"	0.20

LIFELINE TERMINATION STUDS

316 Stainless Steel

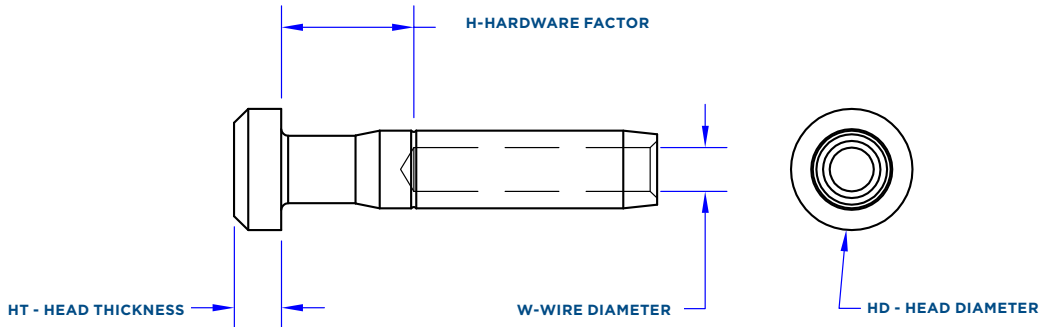

Imperial Wire Sizes - Machine Swage

Part #	W-Wire Ø	HD-Head Ø	HT-Thickness	H-Hardware Factor	Weight lbs.
TSLL18	1/8"	1/2"	7/32"	5/8"	0.02
TSLL532	5/32"	9/16"	7/32"	5/8"	0.04
TSLL316	3/16"	9/16"	7/32"	5/8"	0.05
TSLL14	1/4"	9/16"	7/32"	11/16"	0.07

Metric Wire Sizes - Machine Swage

TSLLM04	4mm	9/16"	7/32"	5/8"	0.04
TSLLM05	5mm	9/16"	7/32"	5/8"	0.05

With Handy Crimp Stud

TSCLL18	1/8"	1/2"	7/32"	1/2"	0.02
TSCLL316	3/16"	9/16"	7/32"	9/16"	0.04

***NOTE: 1/4" and 6mm lifeline fittings use 7/32" (5.5mm) swager dies and specifications.**



ADDITIONAL HARDWARE & TOOLS

- 69** Shackles
- 75** Strap Style Eye Jaw Toggles
- 76** Double Jaw Toggles / Eye Jaw Toggles
- 77** Clevis Pins
- 78** Rigging Pins
- 79** Cotter Pins / Hex Nuts / Circular Ring Pins / Adjuster Nuts
- 80** Pad Eye / Stanchion Eyes / Pulpit Anchor / Clips / Sleeves
- 81** Hold Collars / Conversion Sleeves / Thimbles / Stay Extenders
- 82** Swaging Equipment
- 84** Handy Crimp Tools / Cable Cutters / Instructions



"D" SHACKLES

316 Stainless Steel

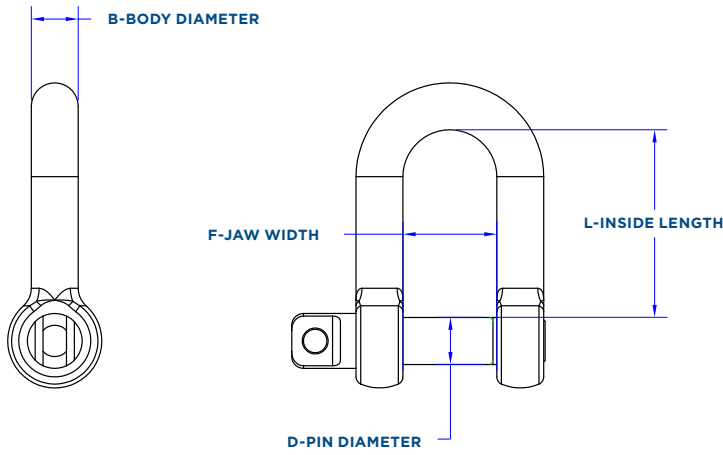

Part #	with Standard Screw Pin	D-Pin Ø	B-Body Ø	F-Jaw Width	L-Inside Length	M.B.L. lbs	Weight lbs.
HM-D04	5/32" D Shackle	5/32"	5/32"	5/16"	5/8"	1,760	0.02
HM-D05	3/16" D Shackle	3/16"	3/16"	3/8"	25/32"	3,300	0.03
HM-D06	1/4" D Shackle	1/4"	1/4"	17/32"	1"	4,290	0.05
HM-D08	5/16" D Shackle	5/16"	5/16"	5/8"	1 9/32"	6,600	0.12
HM-D10	3/8" D Shackle	3/8"	3/8"	3/4"	1 1/2"	10,560	0.21
HM-D11	7/16" D Shackle	7/16"	7/16"	7/8"	1 3/4"	13,200	0.33
HM-D12	1/2" D Shackle	1/2"	1/2"	1 1/32"	2 1/16"	16,500	0.52
HM-D16	5/8" D Shackle	5/8"	9/16"	1 5/32"	2 9/32"	22,046	0.99
HM-D19	3/4" D Shackle	3/4"	5/8"	1 9/32"	2 1/2"	30,800	1.29



with Socket Head Pin

HM-D05C	3/16" Socket Pin D Shackle	3/16"	3/16"	5/32"	25/32"	3,300	0.03
HM-D06C	1/4" Socket Pin D Shackle	1/4"	1/4"	17/32"	1"	4,290	0.05
HM-D08C	5/16" Socket Pin D Shackle	5/16"	5/16"	5/8"	1 9/32"	6,600	0.12
HM-D10C	3/8" Socket Pin D Shackle	3/8"	3/8"	3/4"	1 1/2"	10,560	0.21
HM-D11C	7/16" Socket Pin D Shackle	7/16"	7/16"	7/8"	1 3/4"	13,200	0.33
HM-D12C	1/2" Socket Pin D Shackle	1/2"	1/2"	1 1/32"	2 1/16"	16,500	0.52
HM-D16C	5/8" Socket Pin D Shackle	5/8"	9/16"	1 5/32"	2 9/32"	22,046	0.99
HM-D19C	3/4" Socket Pin D Shackle	3/4"	5/8"	1 9/32"	2 1/2"	30,800	1.29



with Shake Proof Pins

HM-D05RS	3/16" Shake Proof D Retained	3/16"	3/16"	5/32"	25/32"	3,300	0.03
HM-D06RS	1/4" Shake Proof D Retained	1/4"	1/4"	17/32"	1"	4,290	0.05
HM-D08RS	5/16" Shake Proof D Retained	5/16"	5/16"	5/8"	1 9/32"	6,600	0.12
HM-D10RS	3/8" Shake Proof D Retained	3/8"	3/8"	3/4"	1 1/2"	10,560	0.21
HM-D11RS	7/16" Shake Proof D Retained	7/16"	7/16"	7/8"	1 3/4"	13,200	0.33
HM-D12RS	1/2" Shake Proof D Retained	1/2"	1/2"	1 1/32"	2 1/16"	16,500	0.52
HM-D16RS	5/8" Shake Proof D Retained	5/8"	9/16"	1 5/32"	2 9/32"	22,046	0.99

WIDE "D" SHACKLES

316 Stainless Steel

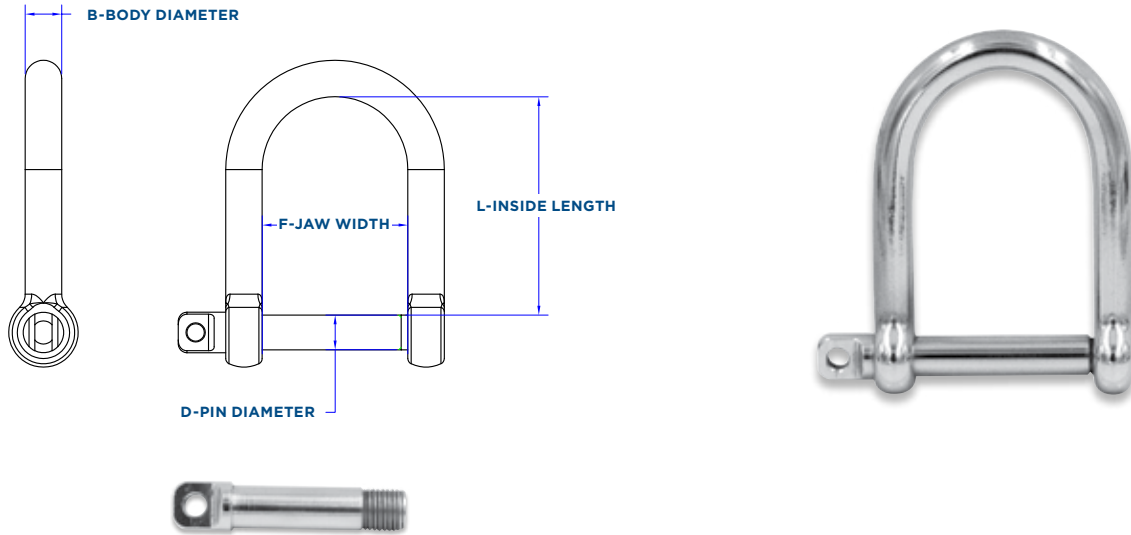

Part #	with Standard Screw Pin	D-Pin Ø	B-Body Ø	F-Jaw Width	L-Inside Length	M.B.L. lbs	Weight lbs.
HM-WD05	3/16" Wide D Shackle	3/16"	3/16"	25/32"	1 3/16"	1,650	0.03
HM-WD06	1/4" Wide D Shackle	1/4"	1/4"	13/32"	1 9/32"	2,860	0.07
HM-WD08	5/16" Wide D Shackle	5/16"	5/16"	1 9/32"	1 29/32"	5,500	0.14
HM-WD10	3/8" Wide D Shackle	3/8"	3/8"	1 1/2"	2 3/8"	7,260	0.26

HIGH RESISTANCE "D" SHACKLES

17/4 PH Stainless Steel

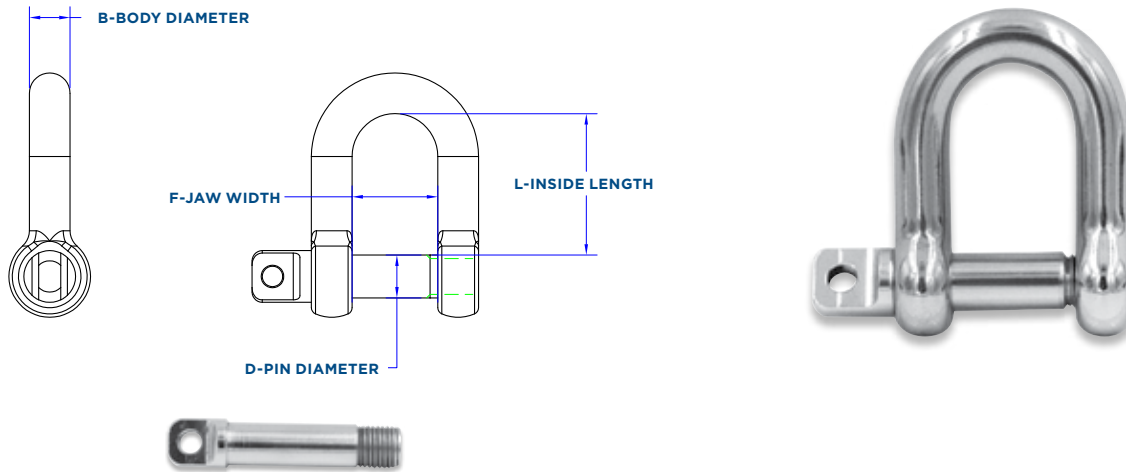

Part #	with Standard Screw Pin	D-Pin Ø	B-Body Ø	F-Jaw Width	L-Inside Length	M.B.L. lbs	Weight lbs.
HM-HRD06	1/4" x 1/4" HR D Shackle	1/4"	1/4"	15/32"	25/32"	5,952	0.05
HM-HRD08	5/16" x 5/16" HR D Shackle	5/16"	5/16"	5/8"	1 1/32"	9,700	0.12
HM-HRD10	3/8" x 3/8" HR D Shackle	3/8"	3/8"	25/32"	1 9/32"	16,535	0.21
HM-HRD12	1/2" x 1/2" HR D Shackle	1/2"	1/2"	15/16"	1 17/32"	22,046	0.52
HM-HRD14	9/16" x 9/16" HR D Shackle	9/16"	9/16"	1 9/32"	2 7/32"	30,865	0.80
HM-HRD16	5/8" x 5/8" HR D Shackle	5/8"	5/8"	1 9/32"	2 3/4"	41,888	1.03
HM-HRD20	3/4" x 3/4" HR D Shackle	3/4"	25/32"	1 1/2"	2 3/4"	61,729	1.33

LONG "D" SHACKLES

316 Stainless Steel

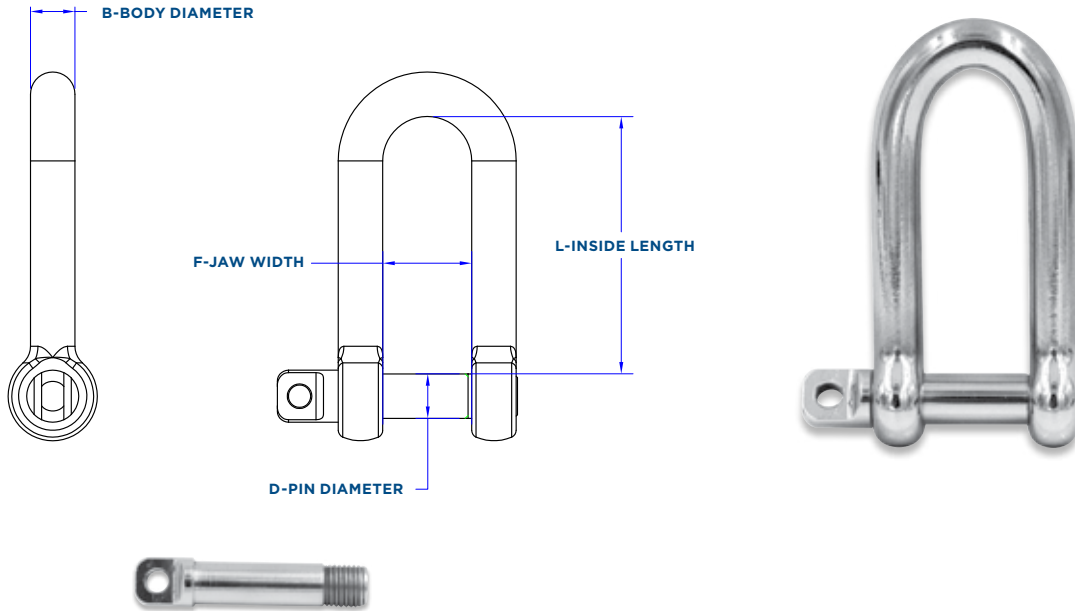

Part #	with Standard Screw Pin	D-Pin Ø	B-Body Ø	F-Jaw Width	L-Inside Length	M.B.L. lbs	Weight lbs.
HM-LD04	5/32" Long D Shackle	5/32"	5/32"	5/16"	15/16"	1,320	0.03
HM-LD05	3/16" Long D Shackle	3/16"	3/16"	13/32"	1 5/32"	2,640	0.04
HM-LD06	1/4" Long D Shackle	1/4"	1/4"	17/32"	1 11/16"	3,520	0.07
HM-LD08	5/16" Long D Shackle	5/16"	5/16"	5/8"	1 29/32"	5,280	0.15
HM-LD10	3/8" Long D Shackle	3/8"	3/8"	3/4"	2 3/16"	8,360	0.26



with Socket Head Pin		D-Pin Ø	B-Body Ø	F-Jaw Width	L-Inside Length	M.B.L. lbs	Weight lbs.
HM-LD05C	3/16" Socket Pin Long D	3/16"	3/16"	13/32"	1 5/32"	2,640	0.04
HM-LD06C	1/4" Socket Pin Long D	1/4"	1/4"	17/32"	1 11/16"	3,520	0.07
HM-LD08C	5/16" Socket Pin Long D	5/16"	5/16"	5/8"	1 29/32"	5,280	0.15
HM-LD10C	3/8" Socket Pin Long D	3/8"	3/8"	3/4"	2 3/16"	8,360	0.26



with Shake Proof Pin		D-Pin Ø	B-Body Ø	F-Jaw Width	L-Inside Length	M.B.L. lbs	Weight lbs.
HM-LD05RS	3/16" Shake Proof Long D Retained	3/16"	3/16"	13/32"	1 5/32"	2,640	0.04
HM-LD06RS	1/4" Shake Proof Long D Retained	1/4"	1/4"	17/32"	1 11/16"	3,520	0.07
HM-LD08RS	5/16" Shake Proof Long D Retained	5/16"	5/16"	5/8"	1 29/32"	5,280	0.15
HM-LD10RS	3/8" Shake Proof Long D Retained	3/8"	3/8"	3/4"	2 3/16"	8,360	0.26

BOW SHACKLES

316 Stainless Steel

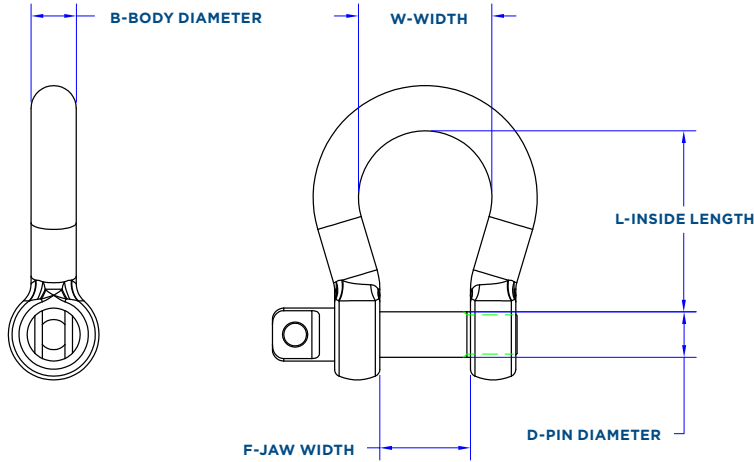

Part #	with Standard Screw Pin	D-Pin Ø	B-Body Ø	F-Jaw Width	L-Inside Length	W-Width	M.B.L. lbs	Weight lbs.
HM-B04	5/32" Bow Shackle	5/32"	5/32"	5/16"	23/32"	15/32"	1,320	0.02
HM-B05	3/16" Bow Shackle	3/16"	3/16"	13/32"	7/8"	5/8"	2,640	0.03
HM-B06	1/4" Bow Shackle	1/4"	1/4"	1/2"	1 1/8"	3/4"	3,520	0.06
HM-B08	5/16" Bow Shackle	5/16"	5/16"	5/8"	1 3/8"	1"	5,280	0.13
HM-B10	3/8" Bow Shackle	3/8"	3/8"	3/4"	1 1/2"	1 1/8"	8,360	0.23
HM-B11	7/16" Bow Shackle	7/16"	7/16"	7/8"	1 13/16"	1 5/16"	10,560	0.35
HM-B12	1/2" Bow Shackle	1/2"	1/2"	1"	2 1/32"	1 1/2"	13,200	0.59
HM-B16	9/16" Bow Shackle	5/8"	9/16"	1 5/32"	2 3/8"	1 11/16"	17,600	1.10
HM-B19	5/8" Bow Shackle	3/4"	5/8"	1 9/32"	2 11/16"	1 31/32"	22,000	1.39



with Socket Head Pin

HM-B05C	3/16" Socket Pin Bow	3/16"	3/16"	13/32"	7/8"	5/8"	2,640	0.03
HM-B06C	1/4" Socket Pin Bow	1/4"	1/4"	1/2"	1 1/8"	3/4"	3,520	0.06
HM-B08C	5/16" Socket Pin Bow	5/16"	5/16"	5/8"	1 3/8"	1"	5,280	0.13
HM-B10C	3/8" Socket Pin Bow	3/8"	3/8"	3/4"	1 1/2"	1 1/8"	8,360	0.23
HM-B11C	7/16" Socket Pin Bow	7/16"	7/16"	7/8"	1 13/16"	1 5/16"	10,560	0.35
HM-B12C	1/2" Socket Pin Bow	1/2"	1/2"	1"	2 1/32"	1 1/2"	13,200	0.59
HM-B16C	5/8" Socket Pin Bow	5/8"	9/16"	1 5/32"	2 3/8"	1 11/16"	17,600	1.10
HM-B19C	3/4" Socket Pin Bow	3/4"	5/8"	1 9/32"	2 11/16"	1 31/32"	22,000	1.39



with Shake Proof Pin

HM-B05RS	3/16" Shake Proof Bow Retained	3/16"	3/16"	13/32"	7/8"	5/8"	2,640	0.03
HM-B06RS	1/4" Shake Proof Bow Retained	1/4"	1/4"	1/2"	1 1/8"	3/4"	3,520	0.06
HM-B08RS	5/16" Shake Proof Bow Retained	5/16"	5/16"	5/8"	1 3/8"	1"	5,280	0.13
HM-B10RS	3/8" Shake Proof Bow Retained	3/8"	3/8"	3/4"	1 1/2"	1 1/8"	8,360	0.23
HM-B11RS	7/16" Shake Proof Bow Retained	7/16"	7/16"	7/8"	1 13/16"	1 5/16"	10,560	0.35
HM-B12RS	1/2" Shake Proof Bow Retained	1/2"	1/2"	1"	2 1/32"	1 1/2"	13,200	0.59
HM-B16RS	5/8" Shake Proof Bow Retained	5/8"	9/16"	1 5/32"	2 3/8"	1 11/16"	17,600	1.10

TWIST SHACKLES

316 Stainless Steel

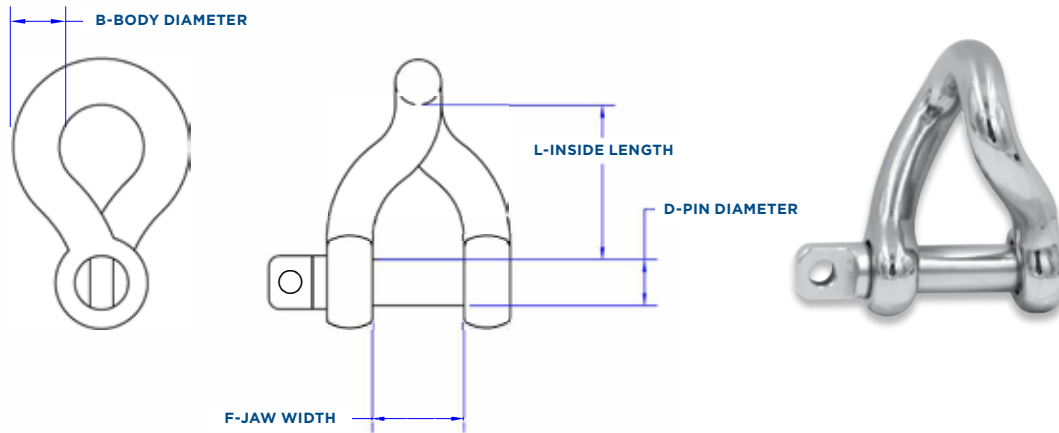

Part #	with Standard Screw Pin	D-Pin Ø	B-Body Ø	F-Jaw Width	L-Inside Length	M.B.L. lbs	Weight lbs.
HM-T04	5/32" Twist Shackle	5/32"	5/32"	5/16"	5/8"	1,320	0.02
HM-T05	3/16" Twist Shackle	3/16"	3/16"	13/32"	11/16"	2,640	0.03
HM-T06	1/4" Twist Shackle	1/4"	1/4"	1/2"	13/16"	3,520	0.05
HM-T08	5/16" Twist Shackle	5/16"	5/16"	5/8"	1 1/32"	5,280	0.12
HM-T10	3/8" Twist Shackle	3/8"	3/8"	3/4"	1 7/32"	8,360	0.21
HM-T11	7/16" Twist Shackle	7/16"	7/16"	7/8"	1 3/8"	10,560	0.33
HM-T12	1/2" Twist Shackle	1/2"	1/2"	1 1/32"	1 3/4"	13,200	0.52
HM-T16	9/16" x 5/8" Twist Shackle	5/8"	9/16"	1 5/32"	1 31/32"	17,600	0.99
HM-T19	5/8" x 3/4" Twist Shackle	3/4"	5/8"	1 9/32"	2 1/4"	24,200	1.29



with Socket Head Pin

HM-T05C	3/16" Socket Pin Twist Shackle	3/16"	3/16"	13/32"	11/16"	2,640	0.03
HM-T06C	1/4" Socket Pin Twist Shackle	1/4"	1/4"	1/2"	13/16"	3,520	0.05
HM-T08C	5/16" Socket Pin Twist Shackle	5/16"	5/16"	5/8"	1 1/32"	5,280	0.12
HM-T10C	3/8" Socket Pin Twist Shackle	3/8"	3/8"	3/4"	1 7/32"	8,360	0.21
HM-T11C	7/16" Socket Pin Twist Shackle	7/16"	7/16"	7/8"	1 3/8"	10,560	0.33
HM-T12C	1/2" Socket Pin Twist Shackle	1/2"	1/2"	1 1/32"	1 3/4"	13,200	0.52
HM-T16C	5/8" Socket Pin Twist Shackle	5/8"	9/16"	1 5/32"	1 31/32"	17,600	0.99
HM-T19C	3/4" Socket Pin Twist Shackle	3/4"	5/8"	1 9/32"	2 1/4"	24,200	1.29



with Shake Proof Pin

HM-T05RS	3/16" Shake Proof Twist Retained	3/16"	3/16"	13/32"	11/16"	2,640	0.03
HM-T06RS	1/4" Shake Proof Twist Retained	1/4"	1/4"	1/2"	13/16"	3,520	0.05
HM-T08RS	5/16" Shake Proof Twist Retained	5/16"	5/16"	5/8"	1 1/32"	5,280	0.12
HM-T10RS	3/8" Shake Proof Twist Retained	3/8"	3/8"	3/4"	1 7/32"	8,360	0.21
HM-T11RS	7/16" Shake Proof Twist Retained	7/16"	7/16"	7/8"	1 3/8"	10,560	0.33
HM-T12RS	1/2" Shake Proof Twist Retained	1/2"	1/2"	1 1/32"	1 3/4"	13,200	0.52
HM-T16RS	5/8" Shake Proof Twist Retained	5/8"	9/16"	1 5/32"	1 31/32"	17,600	0.99

LONG TWIST SHACKLES

316 Stainless Steel

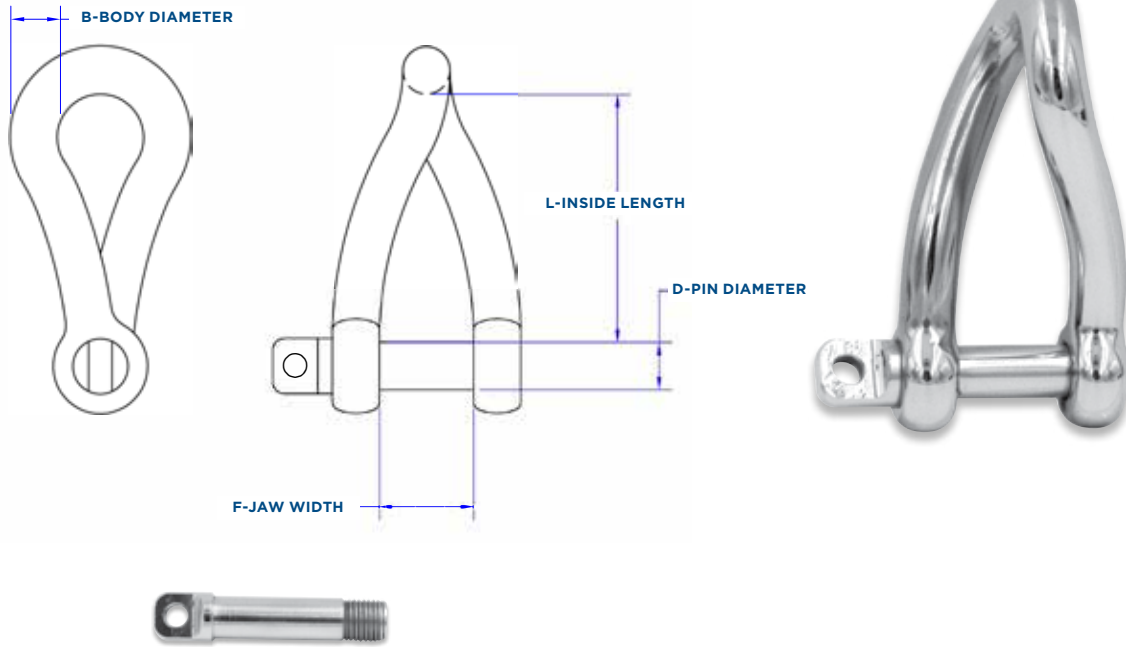

Part #	with Standard Screw Pin	D-Pin Ø	B-Body Ø	F-Jaw Width	L-Inside Length	M.B.L. lbs	Weight lbs.
HM-LT04	5/32" Long Twist Shackle	5/32"	5/32"	5/16"	5/8"	1,320	0.03
HM-LT05	3/16" Long Twist Shackle	3/16"	3/16"	13/32"	1 1/8"	2,640	0.04
HM-LT06	1/4" Long Twist Shackle	1/4"	1/4"	1/2"	1 1/2"	3,520	0.07
HM-LT08	5/16" Long Twist Shackle	5/16"	5/16"	5/8"	1 25/32"	5,280	0.15
HM-LT10	3/8" Long Twist Shackle	3/8"	3/8"	3/4"	1 31/32"	8,360	0.26



with Socket Head Pin

HM-LT05C	3/16" Socket Pin Long Twist	3/16"	3/16"	13/32"	1 1/8"	2,640	0.04
HM-LT06C	1/4" Socket Pin Long Twist	1/4"	1/4"	1/2"	1 1/2"	3,520	0.07
HM-LT08C	5/16" Socket Pin Long Twist	5/16"	5/16"	5/8"	1 25/32"	5,280	0.15
HM-LT10C	3/8" Socket Pin Long Twist	3/8"	3/8"	3/4"	1 31/32"	8,360	0.26



with Shake Proof Pin

HM-LT05RS	3/16" Shake Proof L.Twist Retained	3/16"	3/16"	13/32"	1 1/8"	2,640	0.04
HM-LT06RS	1/4" Shake Proof L.Twist Retained	1/4"	1/4"	1/2"	1 1/2"	3,520	0.07
HM-LT08RS	5/16" Shake Proof L.Twist Retained	5/16"	5/16"	5/8"	1 25/32"	5,280	0.15
HM-LT10RS	3/8" Shake Proof L.Twist Retained	3/8"	3/8"	3/4"	1 31/32"	8,360	0.26

STRAP STYLE EYE JAW TOGGLES (STANDARD CLEVIS STYLE PIN)

316 Stainless Steel

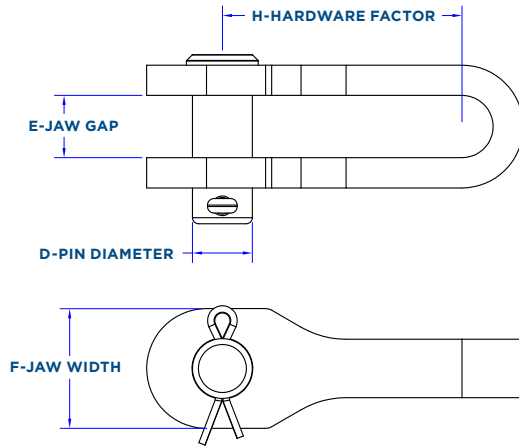

Part #	D-Pin Ø	E-Jaw Gap	F-Jaw Width	H-Hardware Factor	Weight lbs.
EJT38	3/8"	3/8"	3/4"	1 13/16"	0.15
EJT716	7/16"	7/16"	1"	2"	0.23
EJT12	1/2"	1/2"	1"	2 3/16"	0.35
EJT58	5/8"	5/8"	1 1/4"	2 1/2"	0.66
EJT34	3/4"	3/4"	1 1/2"	2 7/8"	1.11
EJT78	7/8"	15/16"	2"	3 5/16"	1.66
EJT1	1"	1"	2"	3 11/16"	2.46

STRAP STYLE EYE JAW TOGGLES (DOUBLE HEAD CLEVIS STYLE PIN)

316 Stainless Steel

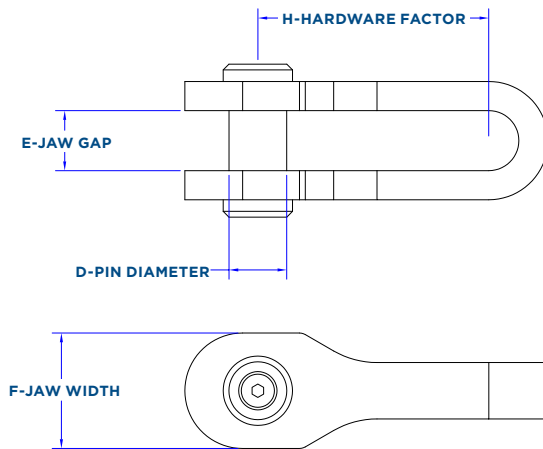

Part #	D-Pin Ø	E-Jaw Gap	F-Jaw Width	H-Hardware Factor	Weight lbs.
EJT38-DHCP	3/8"	3/8"	3/4"	1 13/16"	0.14
EJT716-DHCP	7/16"	7/16"	1"	2"	0.22
EJT12-DHCP	1/2"	1/2"	1"	2 3/16"	0.34
EJT58-DHCP	5/8"	5/8"	1 1/4"	2 1/2"	0.65
EJT34-DHCP	3/4"	3/4"	1 1/2"	2 7/8"	1.08
EJT78-DHCP	7/8"	15/16"	2"	3 5/16"	1.61
EJT1-DHCP	1"	1"	2"	3 11/16"	2.52

DOUBLE JAW TOGGLES

316 Stainless Steel

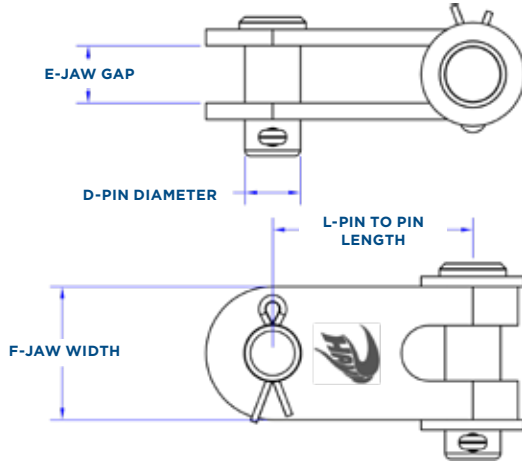

Part #	D-Pin Ø	L-Pin to Pin	E-Jaw Gap	F-Jaw Width	Weight lbs.
14DJT	1/4"	7/8"	1/4"	21/32"	0.07
516DJT	5/16"	31/32"	5/16"	3/4"	0.11
38DJT	3/8"	1 1/4"	3/8"	29/32"	0.17
716DJT	7/16"	1 3/4"	7/16"	1 1/16"	0.24
12DJT	1/2"	1 11/16"	1/2"	1 5/32"	0.41
58DJT	5/8"	2 1/4"	5/8"	1 1/2"	0.79
34DJT	3/4"	2 11/16"	3/4"	1 7/8"	1.44
78DJT	7/8"	4"	7/8"	2 3/8"	2.77
1DJT	1"	3 7/8"	1"	2 1/2"	3.47
118DJT	1 1/8"	4"	1 1/8"	2 3/4"	5.45
114DJT	1 1/4"	5 3/8"	1 1/4"	3 1/4"	6.49
138DJT	1 3/8"	5 15/16"	1 3/8"	4"	11.36

Increased jaw depths available. Call for details.

EYE JAW TOGGLES

316 Stainless Steel

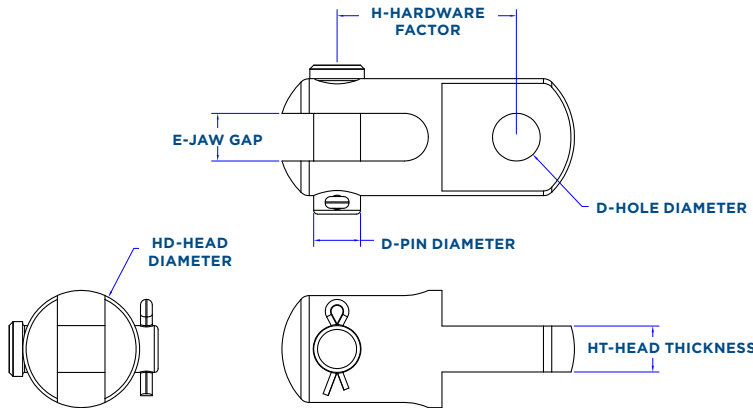

Part #	D-Pin/Hole Ø	E-Jaw Gap	HD-Head Diameter	HT-Head Thickness	H-Hardware Factor	Weight lbs.
TOG03	1/4"	1/4"	9/16"	1/4"	1 1/16"	0.06
TOG04	5/16"	5/16"	23/32"	5/16"	1 5/16"	0.12
TOG05	3/8"	3/8"	7/8"	3/8"	1 9/16"	0.21
TOG06	7/16"	7/16"	1"	7/16"	1 7/8"	0.34
TOG07	1/2"	1/2"	1 1/8"	1/2"	2"	0.48
TOG08	9/16"	9/16"	1 3/8"	9/16"	2 3/16"	0.77
TOG10	5/8"	5/8"	1 1/2"	5/8"	2 11/16"	1.07
TOG12	3/4"	3/4"	1 7/8"	3/4"	2 7/8"	1.89

CLEVIS PINS

316 Stainless Steel

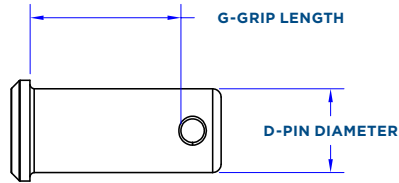

Part #	D-Pin Ø	G-Grip Length	Weight lbs.
SB1	3/16"	9/32"	0.005
SB2	3/16"	13/32"	0.005
SB3	3/16"	9/16"	0.007
SB4	3/16"	3/4"	0.008
SB5	3/16"	15/16"	0.01
SB6	1/4"	1/2"	0.01
SB7	1/4"	9/16"	0.01
CP1458	1/4"	5/8"	0.01
SB8	1/4"	3/4"	0.01
CP1478	1/4"	7/8"	0.01
CP141	1/4"	1"	0.01
CP14118	1/4"	1 1/8"	0.01
CP14114	1/4"	1 1/4"	0.02
CP14112	1/4"	1 1/2"	0.02
516CP	5/16"	9/16"	0.01
BB2	5/16"	11/16"	0.02
CP5161	5/16"	1"	0.02
CP516118	5/16"	1 1/8"	0.03
CP516114	5/16"	1 1/4"	0.03
CP516112	5/16"	1 1/2"	0.04
38CP	3/8"	11/16"	0.03
BB3	3/8"	13/16"	0.03
CP381	3/8"	1"	0.04
CP38114	3/8"	1 1/4"	0.04
CP38112	3/8"	1 1/2"	0.05
CP71634	7/16"	3/4"	0.04
BB4	7/16"	29/32"	0.05
CP7161	7/16"	1"	0.05
12CP	1/2"	7/8"	0.07
BB5	1/2"	1"	0.07
CP12112	1/2"	1 1/2"	0.10
58CP	5/8"	1 1/8"	0.14
BB6	5/8"	1 1/4"	0.14
34CP	3/4"	1 5/16"	0.23
BB7	3/4"	1 9/16"	0.26
BB8	7/8"	1 13/16"	0.39
78CP	7/8"	1 3/4"	0.39
1CP	1"	1 7/8"	0.55
118CP	1 1/8"	2 1/4"	0.79
114CP	1 1/4"	2 1/2"	1.17
138CP	1 3/8"	2 5/8"	1.38

Cotter Pin Part #:

11612C-1

33234C-1

181C-1

532114C-1

316112C-1

142C-1

Replacement Clevis Pins

These pins are highlighted in the adjacent chart.

Usage	Part #
3/16" Pin Adjuster	SB1
3/16" Toggle Jaw	SB2
1/4" Toggle Jaw	SB6
5/16" Toggle Jaw	516CP
3/8" Toggle Jaw	38CP
7/16" Toggle Jaw	716CP
1/2" Toggle Jaw	12CP
5/8" Toggle Jaw	58CP
3/4" Toggle Jaw	34CP
7/8" Toggle Jaw	78CP
1" Toggle Jaw	1CP
1 1/8" Toggle Jaw	115CP
1 1/4" Toggle Jaw	114CP
1 3/8" Toggle Jaw	138CP

RIGGING PINS

316 Stainless Steel

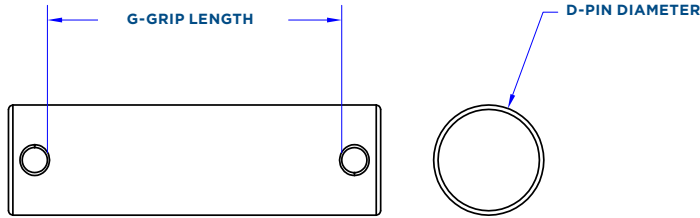

Part #	D-Pin Ø	G-Grip Length	Weight lbs.
RP1434	1/4"	3/4"	0.01
RP1478	1/4"	7/8"	0.01
RP141	1/4"	1"	0.01
RP14118	1/4"	1 1/8"	0.02
RP14114	1/4"	1 1/4"	0.02
RP14112	1/4"	1 1/2"	0.02
RP14134	1/4"	1 3/4"	0.02
RP142	1/4"	2"	0.03
RP14214	1/4"	2 1/4"	0.03
RP14212	1/4"	2 1/2"	0.03
RP14312	1/4"	3 1/2"	0.05
RP51634	5/16"	3/4"	0.02
RP51678	5/16"	7/8"	0.02
RP5161	5/16"	1"	0.02
RP516118	5/16"	1 1/8"	0.03
RP516114	5/16"	1 1/4"	0.03
RP516112	5/16"	1 1/2"	0.03
RP516134	5/16"	1 3/4"	0.04
RP5162	5/16"	2"	0.05
RP516214	5/16"	2 1/4"	0.05
RP516212	5/16"	2 1/2"	0.06
RP516312	5/16"	3 1/2"	0.08
RP3834	3/8"	3/4"	0.03
RP3878	3/8"	7/8"	0.03
RP381	3/8"	1"	0.04
RP38118	3/8"	1 1/8"	0.04
RP38114	3/8"	1 1/4"	0.04
RP38112	3/8"	1 1/2"	0.05
RP38134	3/8"	1 3/4"	0.06
RP382	3/8"	2"	0.07
RP38214	3/8"	2 1/4"	0.08
RP38212	3/8"	2 1/2"	0.08
RP38312	3/8"	3 1/2"	0.11
RP71634	7/16"	3/4"	0.04
RP71678	7/16"	7/8"	0.05
RP7161	7/16"	1"	0.05

Part #	D-Pin Ø	G-Grip Length	Weight lbs.
RP716118	7/16"	1 1/8"	0.06
RP716114	7/16"	1 1/4"	0.07
RP716112	7/16"	1 1/2"	0.08
RP716134	7/16"	1 3/4"	0.09
RP7162	7/16"	2"	0.10
RP716214	7/16"	2 1/4"	0.11
RP716212	7/16"	2 1/2"	0.12
RP716312	7/16"	3 1/2"	0.16
RP121	1/2"	1"	0.08
RP12118	1/2"	1 1/8"	0.08
RP12114	1/2"	1 1/4"	0.09
RP12112	1/2"	1 1/2"	0.10
RP12134	1/2"	1 3/4"	0.11
RP122	1/2"	2"	0.13
RP12214	1/2"	2 1/4"	0.14
RP12212	1/2"	2 1/2"	0.16
RP12312	1/2"	3 1/2"	0.21
RP12612	1/2"	6 1/2"	0.38
RP581	5/8"	1"	0.12
RP58118	5/8"	1 1/8"	0.13
RP58114	5/8"	1 1/4"	0.15
RP58112	5/8"	1 1/2"	0.16
RP58134	5/8"	1 3/4"	0.19
RP582	5/8"	2"	0.21
RP58214	5/8"	2 1/4"	0.23
RP58212	5/8"	2 1/2"	0.25
RP58312	5/8"	3 1/2"	0.34
RP58612	5/8"	6 1/2"	0.61
RP341	3/4"	1"	0.18
RP34114	3/4"	1 1/4"	0.21
RP34112	3/4"	1 1/2"	0.25
RP342	3/4"	2"	0.31
RP34214	3/4"	2 1/4"	0.34
RP34212	3/4"	2 1/2"	0.37
RP34312	3/4"	3 1/2"	0.50

COTTER PINS

304 Stainless Steel

Part #	Size Ø	Grip Length	Weight lbs.
11612C-1	1/16"	1/2"	0.001
116112C-1	1/16"	1 1/2"	0.002
33234C-1	3/32"	3/4"	0.002
332114C-1	3/32"	1 1/4"	0.003
181C-1	1/8"	1"	0.006
18212C-1	1/8"	2 1/2"	0.01
183C-1	1/8"	3"	0.01
532114C-1	5/32"	1 1/4"	0.01
316112C-1	3/16"	1 1/2"	0.01



HEX NUTS

18-8 Stainless Steel

Right Hand Left Hand

Part #	Part #	Thread Size	Weight lbs.
10LNR	10LNL	10-32	0.003
14LNR	14LNL	1/4-28	0.007
516LNR	516LNL	5/16-24	0.01
38LNR	38LNL	3/8-24	0.01
12LNR	12LNL	1/2-20	0.03
58LNR	58LNL	5/8-18	0.07
34LNR	34LNL	3/4-16	0.10
78LNR	78LNL	7/8-14	0.18
1LNR	1LNL	1-12	0.26



CIRCULAR RING PINS

316 Stainless Steel

Part #	Ring Size	Pin Size	Weight lbs.
CR1	3/4"	3/16"-5/16"	0.002
CR2	5/8"	3/16"-5/16"	0.002
CR3	7/16"	3/16"	0.001
CR4	7/8"	5/16"-3/8"	0.004



ADJUSTER NUTS

316 Stainless Steel

Right Hand Left Hand

Part #	Part #	Thread Size	Weight lbs.
10SAN	-	10-32	0.01
14SAN	14ALLARN	1/4-28	0.02



PAD EYE

316 Stainless Steel

Part #	Screw Size	Hole Centers	Weight lbs.
PE1	1/4"	1 1/2" x 2 5/8"	0.18



STANCHION EYES (FOR 1" RAIL SIZE)

316 Stainless Steel

Part #	Loops	Weight lbs.
14SER	1	0.17
14SER2	2	0.16



PULPIT ANCHOR

316 Stainless Steel

Part #	Hole Size	Rail Size	Weight lbs.
14PA	1/2"	1"	0.13



WIRE ROPE CLIPS (FORGED SS)

316 Stainless Steel

Part #	Wire Size	# Required*	Weight lbs.
WRC2	1/8"	2	0.02
WRC4	5/32" - 3/16"	2	0.03
WRC6	7/32" - 1/4"	2	0.16
WRC8	9/32" - 5/16"	2	0.13
WRC10	3/8"	2	0.17
WRC12	1/2"	3	0.51
WRC14	9/16"	3	0.34
WRC16	5/8"	3	0.37



*NOTE: Required # is for full strength of cable.

COPPER OVAL SLEEVES (ZINC COATED)

Zinc Coated Copper

Part #	Wire Size	Weight lbs.
SLC116	1/16"	0.004
SLC332	3/32"	0.005
SLC18	1/8"	0.01
SLC532	5/32"	0.02
SLC316	3/16"	0.05
SLC732	7/32"	0.04
SLC14	1/4"	0.07
SLC516	5/16"	0.13
SLC38	3/8"	0.15

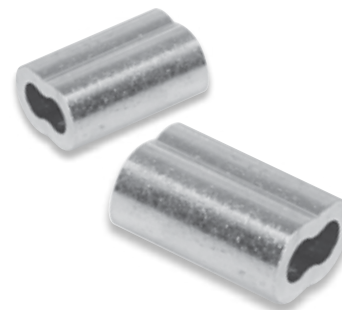

HOLD COLLARS (SIZES FOR COATED CABLE)

316 Stainless Steel

Part #	Wire Size	Hole Size	Weight lbs.
HC18	1/8" - 7/32"	1/4"	0.03
HC316	3/16" - 5/16"	5/16"	0.03
HC38	1/4" - 3/8"	3/8"	0.03

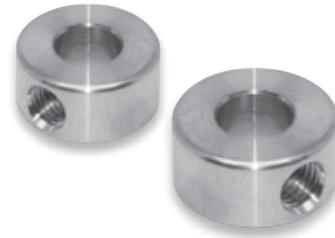

CONVERSION SLEEVES

316 Stainless Steel

Part #	Length	Weight lbs.
CSLL	1"	0.005
CSLLC	2"	0.008



THIMBLES (STANDARD DUTY)

316 Stainless Steel

Part #	Wire Size	A	B	C	Weight lbs.
TH332	3/32"	0.276	0.472	0.827	0.004
TH18	1/8"	0.354	0.551	0.906	0.005
TH532	5/32"	0.433	0.630	1.063	0.007
TH316	3/16"	0.571	0.827	1.220	0.01
TH732	7/32"	0.630	1.024	1.535	0.01
TH14	1/4"	0.728	1.142	1.654	0.02
TH516	5/16"	0.827	1.378	1.969	0.03
TH38	3/8"	1.024	1.654	2.323	0.06
TH12	1/2"	1.220	1.890	2.756	0.08

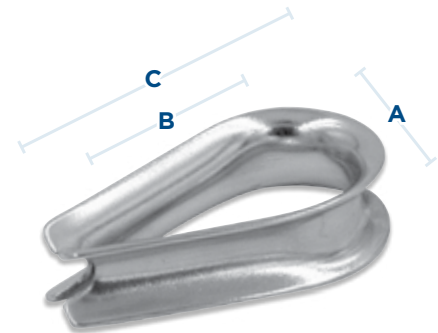

STAY EXTENDERS

316 Stainless Steel

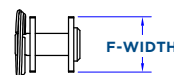
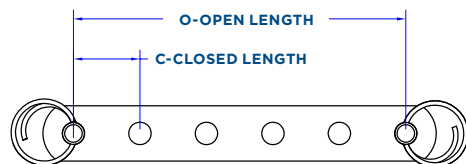
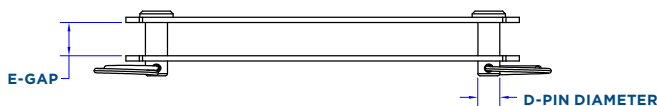

Part #	D-Pin Ø	O-Open Length	C-Closed Length	E - Gap	F-Width	Weight lbs.
14EX	1/4"	3 3/4"	3/4"	3/8" Max.	5/8"	0.10
516EX	5/16"	4 3/8"	7/8"	1/2" Max.	3/4"	0.17
38EX	3/8"	5"	1"	1/2" Max.	1"	0.33
12EX	1/2"	5 5/8"	1 1/8"	5/8" Max.	1 1/4"	0.64
58EX	5/8"	6 1/4"	1 1/4"	5/8" Max.	1 1/2"	1.28
34EX	3/4"	7 13/16"	1 9/16"	3/4" Max.	1 7/8"	2.58

SWAGING EQUIPMENT



Top Reff 2000 K50E Terminal Swaging Machine

- 1/2" wire capacity
- Top quality German made
- Terminal guidance
- Compact self-contained foot controls for hands free operation
- Quick-change dies
- Powers in both directions
- 110 volt power source
- Terminals from 3/32" - 1/2"
- Base machine weight 154 lbs.

Hayn offers two professional grade swaging solutions which can be tailored to your specific needs:

WireTeknik Brand: Made in Sweden, these units range in size from small portable to stationary units capable of swaging cable sizes over 1-1/2". These versatile units can be powered by hand pump, air hydraulic, battery drill hydraulic, or electro hydraulic depending on your specific needs. The simple yet robust design pulls the fittings through the dies for a true straight swage every time. Hayn stocks the WireTeknik line with a complete inventory of machines, power packs, dies, and pulling attachments.

Top Reff 2000 Brand: Made in Germany, this self contained, highly compact unit is capable of high capacity production swaging. These units feature fully powered dies that eliminate the need for separate pulling attachments. Hayn stocks a complete line of die sizes.

Our trained staff will help evaluate your needs and recommend a solution that fits your toughest demands. Hayn offers complete maintenance services for both brands offered and has loaner units, if necessary, to eliminate any costly down time.

Top Reff Swagers / Dies

Top Reff Swager K50E 1/16"-1/2"	K50E
TOP REFF 2000 K50 DIES - 3/32" WIRE	K50E332
TOP REFF 2000 K50 DIES - 1/8" WIRE	K50E18
TOP REFF 2000 K50 DIES - 5/32" WIRE	K50E532
TOP REFF 2000 K50 DIES - 3/16" WIRE	K50E316
TOP REFF 2000 K50 DIES - 7/32" WIRE	K50E732
TOP REFF 2000 K50 DIES - 1/4" WIRE	K50E14
TOP REFF 2000 K50 DIES - 9/32" WIRE	K50E932
TOP REFF 2000 K50 DIES - 5/16" WIRE	K50E516
TOP REFF 2000 K50 DIES - 3/8" WIRE	K50E38
TOP REFF 2000 K50 DIES - 7/16" WIRE	K50E716
TOP REFF 2000 K50 DIES - 1/2" WIRE	K50E12

Top Reff K50E Foot Switch

K50EFOOTSWITCH



Hand Pump - 30 cu. in. - Single Speed



ZAP102 Air Hydraulic Power Pack

NOTE: Standard discounts do not apply to the tools on this page.

SWAGING EQUIPMENT (CONTINUED)



A-100

WireTeknik Roll Swagers / Dies

WireTeknik Roll Swager 1/16" - 3/16" Wire

A-100

Optional Battery Drill Power Unit Available

A-100 SWAGER DIES - 3/32" - 2.5mm

A10332

A-100 SWAGER DIES - 1/8" - 3mm

A1018

A-100 SWAGER DIES - 5/32" - 4mm

A10532

A-100 SWAGER DIES - 3/16" - 5mm

A10316

WireTeknik Roll Swager 1/16" - 5/16" Wire

A-200

Optional Battery Drill Power Unit Available

A-200 SWAGER DIES - 1/16" - 1.6mm

A20116

A-200 SWAGER DIES - 3/32" - 2.5mm

A20332

A-200 SWAGER DIES - 1/8" - 3mm

A2018

A-200 SWAGER DIES - 5/32" - 4mm

A20532

A-200 SWAGER DIES - 3/16" - 5mm

A20316

A-200 SWAGER DIES - 7/32" - 5.5mm

A20732

A-200 SWAGER DIES - 1/4" - 6mm

A2014

A-200 SWAGER DIES - 9/32" - 7mm

A20932

A-200 SWAGER DIES - 5/16" - 8mm

A20516

WireTeknik Roll Swager 3/32" - 1/2" Wire

A-270

Optional Battery Drill Power Unit - Max. wire 3/8"

A-270/A-350 SWAGER DIES - 3/32" - 2.5mm

A250332

A-270/A-350 SWAGER DIES - 1/8" - 3mm

A25018

A-270/A-350 SWAGER DIES - 5/32" - 4mm

A250532

A-270/A-350 SWAGER DIES - 3/16" - 5mm

A250316

A-270/A-350 SWAGER DIES - 7/32" - 5.5mm

A250732

A-270/A-350 SWAGER DIES - 1/4" - 6mm

A25014

A-270/A-350 SWAGER DIES - 9/32" - 7mm

A250932

A-270/A-350 SWAGER DIES - 5/16" - 8mm

A250516

A-270/A-350 SWAGER DIES - 3/8" - 10mm

A25038

A-270/A-350 SWAGER DIES - 7/16" - 11mm

A250716

A-270/A-350 SWAGER DIES - 1/2" - 12mm

A25012



A-200



A-270



A-350



A-400

WireTeknik Roll Swager 3/32" - 5/8" Wire

A-350

Optional Battery Drill Power Unit - Max. wire 9/16"

A-350 SWAGER DIES ONLY - 9/16" - 14mm

A30916

A-350 SWAGER DIES ONLY - 5/8" - 16mm

A3058

WireTeknik Roll Swager 3/8" - 1 1/8" Wire

A-400

A-400 SWAGER DIES - 3/8" - 10mm

A4038

A-400 SWAGER DIES - 7/16" - 11mm

A40716

A-400 SWAGER DIES - 1/2" - 12mm

A4012

A-400 SWAGER DIES - 9/16" - 14mm

A40916

A-400 SWAGER DIES - 5/8" - 16mm

A4058

A-400 SWAGER DIES - 3/4" - 19mm

A4034

A-400 SWAGER DIES - 7/8" - 22mm

A4078

A-400 SWAGER DIES - 1" - 25mm

A401

A-400 SWAGER DIES - 1 1/8" - 28mm

A40118



A-500

WireTeknik Roll Swager 5/8" - 1 1/2" Wire

A-500

Air Hydraulic Power Pack

ZAP102

Hand Pump - 30 cu in. - Single Speed

HYDHANDPUMP

Electric Hydraulic Power Pack (110v)

ELEC-HYD-PWRPK

Battery Drill Power Unit - Max wire 9/16"

BDHPP



Battery Drill Power Unit

NOTE: Standard discounts do not apply to the tools on this page.

HANDY CRIMP TOOLS / CABLE CUTTERS

Our Handy Crimp hardware and our **Nicopress** hand tool shown on this page are for use in low load applications only. When properly installed, these fittings **develop approximately 70% of 7x7 cable strength**. Please refer to our swage type hardware and professional swaging for high load applications.

The crimping process of this hardware is labor intensive and leaves three distinct crimp marks on the fitting, unlike machine swaging which produces a smooth finish.

Handy Crimp hardware is available for 1/8" and 3/16" wire.

Handy Crimp Tool

Lifeline use only

"C" die 1/8" cable
 "G" die 3/16" cable

Part # HCTOOL



Cable Cutters

Cuts Wire up to	Part #
1/8"	CUTC7
3/16"	CUTC9
1/4"	CUTC12
3/8"	CUTC16



NOTE: Standard discounts do not apply to the tools on this page.

HANDY CRIMP INSTRUCTIONS

Fig #1 Use a sharp knife to strip vinyl cover (if required).

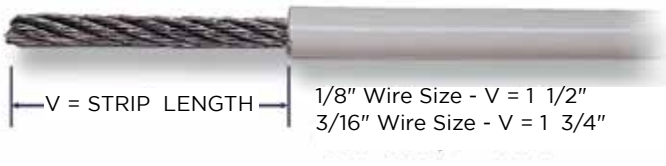

Step #1 Make sure you have the proper equipment and all parts required.

Step #2 If you are using vinyl coated cable it will be necessary to strip back the coating as shown in Fig #1.

Step #3 Insert stripped cable into Handy Crimp fitting and crimp 3 times as shown in Fig #2.

Fig #2 Install 3 crimps 1/8" from end of fitting and 1/8" apart, rotate 90 degrees for each crimp to ensure straightness of fitting.



Step #4 Attach the crimped on end fitting to connection point. Run cable to other connection point. Ensure hardware is adjusted to 2/3rds open position.

Step #5 Attach un-crimped Handy Crimp fitting to other connection point and pull cable tightly along side. Measure for cut as shown in Fig #3.

Fig #3 Attach the second fitting making sure to pull the cable tight before measuring the cut.



Step #6 Repeat steps #2 and #3 for un-crimped end fitting.

Step #7 All crimps must be inspected utilizing a Micrometer or Caliper to the following specifications:

- 1/8" Wire - 0.185**
- 3/16" Wire - 0.265**



Refer to Fig #1 for vinyl coated cable instructions.



HAYN LINES STAINLESS STEEL CABLE SYSTEMS

For additional information:

Phone: **800-346-4296**

E-mail: **cables@hayn.com**

Web: **www.haynlines.com**



Hayn Lines

tel 800-346-4296 fax 800-441-4296

PROMOTIONAL MATERIALS

RETAIL PACK INFORMATION "-RP" SUFFIX

Hayn Rigging and Lifeline Hardware is available in Retail Packaging at no additional charge. When placing your order indicate this by including the suffix "-RP" to the end of the part number. Each pack will come with individual bar code labels which include Part Number, UPC Codes, and Part Description. Please note that both the part number and the UPC code will be different from the standard wholesale part number.



HAYN MARINE RETAIL SIGNS

Hayn Marine Retail Signs are available to wholesale accounts. Signs are made of translucent blue plastic with white vinyl lettering and come in multiple sizes.

Part #	Length	Width	Color Combination
HYN-SIGN-22x8	22"	8"	Translucent Blue / White Lettering
HYN-SIGN-26x12	26"	12"	Translucent Blue / White Lettering
HYN-SIGN-32X16	32"	16"	Translucent Blue / White Lettering



HAYN MARINE RIGGING SHOP BANNERS

Hayn Marine Rigging Shop Banners are available to wholesale accounts. Banners are solid blue with single sided white printed lettering. These banners have hemmed edges and corner grommets for durability.

Part #	Length	Width	Color Combination
HYN-BAN-34x18	34"	18"	Solid Blue / White Lettering
HYN-BAN-48x24	48"	24"	Solid Blue / White Lettering



HAYN CATALOGS

This Hayn Wire Rigging Products Catalog is available to riggers and wholesale customers free of charge.

Part #	Description
CAT-WR-PPE	Hayn Wire Rope Rigging Products Catalog
CAT-ARCH	Hayn Lines Architectural Products Catalog

Please contact Hayn directly if you have other marketing ideas or needs for your rigging shop, retail store, trade show display, etc.



CONTACT INFORMATION

General Inquiries

sales@hayn.com

Architectural Products

cables@hayn.com

Marine Products

marine@hayn.com

Customer Service

customerservice@hayn.com

General Manager

generalmanager@hayn.com

Accounts Receivable

accountsreceivable@hayn.com



Hayn Enterprises, LLC uses the following trade names:

- Hayn Marine
- Hayn Lines
- Hayn Yacht Hardware
- Hayn Industries
- Hayn Muscle
- Metalcraft Products



Hayn Marine hardware is sold to trade professionals only. Please call 800-346-4296 for the Dealer nearest you.